

3745 Communication Controller All Models
3746 Nways Multiprotocol Controller Model 900

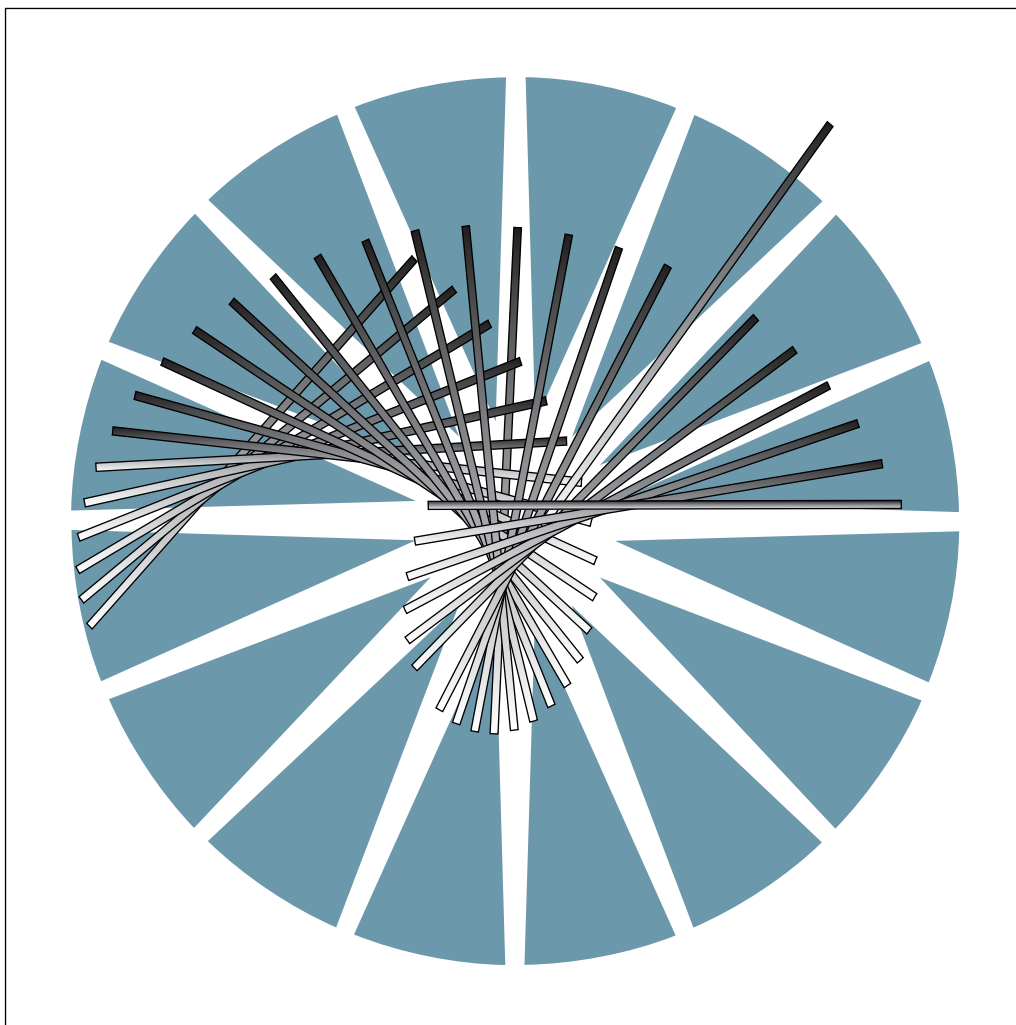

Connection and Integration Guide



3745 Communication Controller All Models
3746 Nways Multiprotocol Controller Model 900



Connection and Integration Guide

Note!

Before using this information and the product it supports, be sure to read the general information under "Notices" on page xi.

Eleventh Edition (May 1997)

The information contained in this guide is subject to change from time to time. Any such changes will be reported in later revisions.

Order publications through your IBM representative or the IBM branch office serving your locality. Publications are not stocked at the address given below.

A form for readers' comments appears at the back of this publication. If the form has been removed, address your comments to:

IBM France
Centre d'Etudes et Recherches
Service 0798 - BP 79
06610 La Gaude,
France

- FAX: 33 4 93 24 77 97
- E-mail: FRIBMQF5 at IBMMAIL
- IBM Internal Use: LGERCF at LGEPROFS
- Internet: rcf_lagaude@vnet.ibm.com

When you send information to IBM, you grant IBM a non-exclusive right to use or distribute the information in any way it believes appropriate without incurring any obligation to you.

© **Copyright International Business Machines Corporation 1988, 1997. All rights reserved.**

Note to U.S. Government Users — Documentation related to restricted rights — Use, duplication or disclosure is subject to restrictions set forth in GSA ADP Schedule Contract with IBM Corp.

Contents

Figures	vii
Tables	ix
Notices	xi
European Union (EU) Statement	xi
Electronic Emission Notices	xi
Trademarks and Service Marks	xii
Safety	xiii
Safety Notices for United Kingdom	xiii
About this Guide	xv
Conventions Used in this Guide	xv
Who Should Use this Guide	xv
How this Guide is Organized	xvi
What is New in this Guide	xvi
Where to Find More Information	xvii
World Wide Web	xvii

Part 1. Connecting

Chapter 1. 3745 Models 210 to 61A: Connecting LICs and Cables	1-1
Getting Started	1-2
Unplugging or Plugging In an Ethernet LAN AUI Cable	1-7
Unplugging or Plugging In a Token-Ring Adapter (TRA) Cable	1-11
Unplugging or Plugging In a High-Speed Scanner (HSS) Cable	1-13
Unplugging or Plugging In an Operator Console Cable	1-15
Unplugging or Plugging In the Remote Support Facility (RSF) Cable	1-16
Removing or Installing the Customer Power Control (CPC) Cable	1-18
Removing or Installing a Line Interface Coupler (LIC) or Its Cable	1-18
Chapter 2. 3745 Models 130 to 17A: Connecting LICs and Cables	2-1
Getting Started	2-2
Unplugging or Plugging In an Ethernet LAN AUI Cable	2-4
Unplugging or Plugging In a Token-Ring Adapter (TRA) Cable	2-7
Unplugging or Plugging In a High-Speed Scanner (HSS) Cable	2-8
Unplugging or Plugging In an Operator Console Cable	2-9
Unplugging or Plugging In the Remote Support Facility (RSF) Cable	2-11
Removing or Installing the Customer Power Control (CPC) Cable	2-12
Removing or Installing a Line Interface Coupler (LIC) or Its Cable	2-13
Chapter 3. 3746-900: Installing LCBs and ARCs, Connecting Cables	3-1
Connection Tasks	3-2
Starting Connection Tasks	3-2
Unplugging or Plugging in a TIC3 Cable	3-5
Unplugging or Plugging in LIC Cables	3-7
Unplugging or Plugging In an Ethernet LAN Cable	3-9
Unplugging or Plugging In an AUI Cable	3-9
Unplugging or Plugging In a 10BASE-T Cable	3-11

Unplugging or Plugging in a Multiaccess Enclosure Adapter Cable	3-12
Installing an LCB	3-13
Removing or Installing ARC Assembly A	3-18
Removing or Installing ARC Assembly B	3-24

Part 2. Integrating

Chapter 4. Starting the 3745 Integration	4-1
Starting Procedure	4-1
Chapter 5. Integration Procedures	5-1
MOSS-E Integration Functions (3746-900 Only)	5-1
Initial Installation	5-1
Updating the Active CDF-E (3746-900 Only)	5-1
Saving the Controller Configuration	5-5
MOSS Integration Procedures	5-5
Integrating an Initial Installation	5-6
Integrating a Later Modification	5-6
Conventions Used in this Chapter for the MOSS	5-6
Upgrading or Updating CDF	5-7
When to Use Upgrade or Update	5-7
Upgrade Procedure	5-8
Update Procedure	5-10
Changing Passwords on the 3745 MOSS	5-14
Setting Power On Schedule	5-16
Updating Link IPL Ports	5-17
IPL Ports on 3745 (All Models)	5-17
Link IPL Ports on 3746-900.	5-18
IPL and Loading the Network Control Program	5-18
Saving MOSS from Fixed Disk onto Diskettes	5-19
Putting the MOSS On-Line	5-21

Part 3. Appendices

Appendix A. LSS Characteristics and Line Weights	A-1
Characteristics of the LSSs	A-1
Line Weight Calculation	A-1
Scanner Capacity	A-2
Mixing Line Interface Couplers	A-3
Spare Lines	A-3
Selective Scanning	A-3
Appendix B. Communication Line Processor Characteristics and Line Weights	B-1
Characteristics of the CLPs	B-1
Communication Line Processor Connectivity	B-1
Characteristics of LIC Types 11, 12, and 16	B-2
Maximum Configuration of a 3745 with a 3746-900	B-3
Configuring Communication Lines on the 3746-900 (Line Weights)	B-4
CF3745 Hardware Configurator (Standard Line Weights)	B-4
Appendix C. Bibliographies	C-1

Customer Documentation for the IBM 3745 (Models 210, 310, 410, 610, 21A,
31A, 41A, and 61A), and 3746 (Model 900) C-1
Additional Customer Documentation for the IBM 3745 Models 130, 150, 160,
170, and 17A C-5

Abbreviations, Glossary, and Index

List of Abbreviations X-1
Glossary X-3
Index X-9

Figures

1-1.	3745 Models 210 to 61A Base Frame Rear View	1-4
1-2.	Four Possible Configurations of Area A	1-5
1-3.	3745 Models 210 to 610: Service Connectors	1-6
1-4.	3745 Models 21A to 61A: Service Connectors	1-7
1-5.	LIC Types 1, 3, and 4.	1-20
1-6.	3745 Cable Arrangement	1-24
2-1.	Non-LIC Connector Location	2-3
2-2.	LIC Types 1, 3 and 4.	2-15
3-1.	ARC Assembly A and B	3-2
3-2.	3746-900 Rear View (the Coupler Side)	3-3
3-3.	Addresses for the Enclosures	3-3
3-4.	3746-900 LCBs Locations Example in the Base Frame and the Controller Expansion.	3-4
3-5.	Installing or Removing a Token-Ring Attachment Cable	3-5
3-6.	Installing or Removing a Token-Ring UTP Cable and Media Filter	3-6
3-7.	The LIC 11, LIC 12, LIC 16, and Their Cables	3-8
3-8.	LCB Base	3-14
3-9.	LCB Expansion	3-14
3-10.	LCB Base and LCB Expansion Connections Installed with ARC Assembly A.	3-15
3-11.	LCB Grounding	3-16
3-12.	Standard Grounding Connection	3-17
3-13.	ARC Assembly A and B	3-18
3-14.	ARC Assembly A in an LCB	3-20
3-15.	The ARC Assembly A and Its Different Types of Connector	3-21
3-16.	IBM 3745-Type Connector	3-22
3-17.	French V.35 DCE Adapter	3-23
3-18.	French V.35 DTE Adapter	3-23
3-19.	ARC Assembly A and B	3-24
3-20.	ARC Assembly B in an LCB	3-26
3-21.	The ARC Assembly B and Its Different Types of Connector	3-27
3-22.	IBM 3745-type Connector	3-28
3-23.	French V.35 DCE Adapter	3-29
3-24.	French V.35 DTE Adapter	3-29

Tables

A-1.	LIC 1 Through LIC 4 Characteristics	A-1
A-2.	Line Weight Calculation for LIC types 1, 3, 4A and 4B	A-1
A-3.	One-Port LICs - LIC Types 3 and 4B	A-2
A-4.	One-Port LICs - LIC Types 1 and 4A	A-2
B-1.	Characteristics of the LIC Types 11, 12 and 16	B-2
B-2.	Maximum Configurations of the 3745s with an Attached 3746-900	B-3
B-3.	Assumed Line Utilization (Duplex)	B-4
B-4.	Assumed Traffic Mix	B-4
B-5.	Standard Line Weights	B-5
B-6.	Standard CLP Connectivity	B-6
C-1.	Customer Documentation for the 3745 Models x10 and x1A, and 3746 Model 900	C-1
C-2.	Additional Customer Documentation for the 3745 Models 1x0 and 17A	C-5

Notices

References in this publication to IBM products, programs, or services do not imply that IBM intends to make these available in all countries in which IBM operates. Any reference to an IBM product, program, or service is not intended to state or imply that only IBM's product, program, or service may be used. Any functionally equivalent product, program, or service that does not infringe any of IBM's intellectual property rights may be used instead of the IBM product, program, or service. Evaluation and verification of operation in conjunction with other products, except those expressly designated by IBM, is the user's responsibility.

IBM may have patents or pending patent applications covering subject matter in this document. The furnishing of this document does not give you any license to these patents. You can send license inquiries, in writing, to the IBM Director of Licensing, IBM Corporation, 500 Columbus Avenue, Thornwood, New York 10594, U.S.A.

European Union (EU) Statement

This product is in conformity with the protection requirements of EU Council Directive 89/336/EEC on the approximation of the laws of the Member States relating to electromagnetic compatibility. IBM can not accept responsibility for any failure to satisfy the protection requirements resulting from a non-recommended modification of the product, including the fitting of non-IBM option cards.

Electronic Emission Notices

Federal Communications Commission (FCC) Statement

Note: This equipment has been tested and found to comply with the limits for a Class A digital device, pursuant to Part 15 of the FCC Rules. These limits are designed to provide reasonable protection against harmful interference when the equipment is operated in a commercial environment. This equipment generates, uses, and can radiate radio frequency energy and, if not installed and used in accordance with the instruction manual, may cause harmful interference to radio communications. Operation of this equipment in a residential area is likely to cause harmful interference, in which case the user will be required to correct the interference at his own expense.

Properly shielded and grounded cables and connectors must be used in order to meet FCC emission limits. IBM is not responsible for any radio or television interference caused by using other than recommended cables and connectors or by unauthorized changes or modifications to this equipment. Unauthorized changes or modifications could void the user's authority to operate the equipment.

This device complies with Part 15 of the FCC Rules. Operation is subject to the following two conditions: (1) this device may not cause harmful interference, and (2) this device must accept any interference received, including interference that may cause undesired operation.

Industry Canada Compliance Statement

This Class A digital apparatus meets all requirements of the Canadian Interference-Causing Equipment Regulations.

Avis de conformité aux normes d'Industrie Canada

Cet appareil numérique de la classe A respecte toutes les exigences du Règlement sur le matériel brouilleur du Canada.

Japanese Voluntary Control Council For Interference (VCCI) Statement

This equipment is in the 1st Class category (information equipment to be used in commercial and/or industrial areas) and conforms to the standards set by the Voluntary Control Council for Interference by Information Technology Equipment aimed at preventing radio interference in commercial and industrial areas.

Consequently, when used in a residential area or in an adjacent area thereto, radio interference may be caused to radios and TV receivers, and so on.

Read the instructions for correct handling.

Korean Communications Statement

Please note that this device has been approved for business purpose with regard to electromagnetic interference. If you find this is not suitable for your use, you may exchange it for a non-business one.

New Zealand Radiocommunications (Radio) Regulations

Attention: This is a Class A product. In a domestic environment this product may cause radio interference in which case the user may be required to take adequate measures.

Trademarks and Service Marks

The following terms, denoted by an asterisk (*), used in this publication, are trademarks or service marks of IBM Corporation in the United States or other countries:

Advanced Peer-to-Peer
ESCON
NetView
RETAIN
VTAM

APPN
IBM
Nways
System/370

Safety

This product meets IBM* safety standards.

For more information, see the *Safety Information*, GA33-0400.

Safety Notices for United Kingdom

1. The IBM 3746 Nways Multiprotocol Controller Model 900 is manufactured according to the International Safety Standard EN 60950 and as such is approved in the UK under the General Approval Number NS/G/1234/J/100003 for indirect connection to the public telecommunication network.
2. The network adapter interfaces housed within the IBM 3746 Nways Multiprotocol Controller Model 900 are approved separately, each one having its own independent approval number. These interface adapters, supplied by IBM, do not use or contain excessive voltages. An excessive voltage is one that exceeds 42.4 V peak ac or 60 V dc. They interface with the IBM 3746 Nways Multiprotocol Controller Model 900 using Safety Extra Low Voltages (SELV) only. In order to maintain the separate (independent) approval of the IBM adapters, it is essential that other optional cards, not supplied by IBM, do not use mains voltages or any other excessive voltages. Seek advice from a competent engineer before installing other adapters not supplied by IBM.

About this Guide

This guide applies to the:

- IBM 3745 Communication Controller Models 130 to 17A and Models 210 to 61A (3745)
- IBM 3746 Nways* Multiprotocol Controller Model 900 operating as:
 - SNA subareas (3746-900)
 - APPN*/HPR Network Node (3746-900NN)
 - IP Router (3746-900IP).

It contains information for the following types of tasks:

- Connecting line cables
- Integrating the network.

These tasks are performed at initial installation and during later modifications of your IBM 3745 Communication Controller or 3746 Nways Multiprotocol Controller Model 900.

Conventions Used in this Guide

Throughout this guide the term:

3745	Refers to the IBM 3745 (Models 130 to 170 and 210 to 610) with any Expansion Unit (Models A11, A12, L13, L14, and L15) that may be installed.
3745 Model A	Refers to the IBM 3745 (Models 17A, 21A, 31A, 41A and 61A) with any Expansion Unit (Models A11, A12, L13, L14, L15, or 900).
3746-900	Refers to the IBM 3746 Nways Multiprotocol Controller Model 900.
3746-900NN	Refers to the part of the 3746-900 operating as an Advanced Peer-to-Peer Networking*/High Performance Routing (APPN/HPR) Network Node.
3746-900IP	Refers to the part of the 3746-900 operating as an IP Router.
SNA	Refers to the first generation of the Systems Network Architecture (SNA) with subareas and Communication Controllers running ACF/NCP. That is host-dependent networking.
APPN	Refers to the Advanced Peer-to-Peer (APPN) architectural extension of SNA. An APPN network is an SNA network that uses network nodes. That is distributed networking.
HPR	Extension of the APPN architecture that takes advantage of fast links with low error rate.

Who Should Use this Guide

This guide is intended for personnel who are responsible for the initial installation and later configuration changes of the 3745/3746-900, such as:

- Network generalists
- System programmers
- System service personnel

- IBM 3745/3746-900 trained service representatives.

The user should have an understanding of teleprocessing, modem operations, and Advanced Peer-to-Peer Networking/High Performance Routing (APPN/HPR).

Teleprocessing specialists should use also:

- The on-line information (help, guides and other materials) for:
 - The Maintenance and Operator Sub-System - Extended (MOSS-E)
 - The Controller Configuration and Management (CCM)
 - The Multiaccess Enclosure Management (IBM 2216 base)
 - The APPN/HPR and IP control points functions
 - The TCP/IP environment.
- The publications listed in Appendix C, "Bibliographies."

How this Guide is Organized

This guide describes the user tasks for connecting and integrating lines to the 3745/3746-900.

Important

Before starting a procedure, ensure you are familiar with the general information at the beginning of its chapter and know the requirements for the procedure.

This guide contains the following parts:

Part 1. Connecting, describes the connection tasks for the hardware: the LICs, TICs, LCBs, ARCs, and the cables for the various types of communication and service lines.

Part 2. Integrating, explains the procedures used to integrate hardware and software configuration changes into the network.

Part 3. Appendices, has two appendices which explain how to calculate the low-speed scanner (LSS), and LIC types 11, 12, and 16 line weights.

At the back of this guide is a list of abbreviations, a glossary, and the index.

What is New in this Guide

This revised edition gives information concerning:

- "Unplugging or Plugging in a Multiaccess Enclosure Adapter Cable" on page 3-12.
- Connectivity improvement in Appendix B, "Communication Line Processor Characteristics and Line Weights."

Where to Find More Information

“Customer Documentation for the IBM 3745 (Models 210, 310, 410, 610, 21A, 31A, 41A, and 61A), and 3746 (Model 900)” on page C-1

“Additional Customer Documentation for the IBM 3745 Models 130, 150, 160, 170, and 17A” on page C-5

Networking Softcopy Collection Kit, SK2T-6012.

World Wide Web

You can access the latest news and information about IBM network products, customer service and support, and microcode upgrade via Internet at the URL:

<http://www.ibm.com>

Part 1. Connecting

This part consists of three chapters which describe the procedures for changing user-accessible hardware (located in a reserved area) by qualified customer personnel:

- Chapter 1, 3745 Models 210 to 61A: Connecting LICs and Cables, and
- Chapter 2, 3745 Models 130 to 17A: Connecting LICs and Cables, describe the procedures for changing:
 - Line interface couplers
 - Line interface coupler cables
 - High-speed scanner cables
 - Token-ring adapter cables
 - Ethernet LAN AUI cables
 - Operator console cables
 - Remote support facility cable
 - Customer power control cable.
- Chapter 3, 3746-900: Installing LCBs and ARCs, Connecting Cables, describes the procedures for changing:
 - Ethernet Bridge cables
 - Multiaccess Enclosure cables
 - Token-ring interface coupler type 3 cables
 - Line interface coupler types 11, 12, and 16 cables
 - Line connection boxes (LCBs)
 - Active remote connection (ARC) assemblies and cables.

These procedures are performed at **initial** installation and during **later** modifications of your 3745, 3745 Models A and 3746-900.

Initial installation refers to the first installation of your 3745, 3745 Models A and 3746-900 or its re-installation after moving the machine. This is done with the help of the IBM service representative.

Later modifications refer to changes made at any other time. These later modifications do not require a service representative.

Notes:

1. While using the procedures in this part, the 3745/3746-900 can be powered ON.
2. For the **3746-900**, only the TIC3 cables can be changed by the user. Adding, removing, or changing the TIC3s themselves is done by the IBM service representative.

Chapter 1. 3745 Models 210 to 61A: Connecting LICs and Cables

This chapter gives all the procedures for the 3745 (Models 210 to 61A) hardware connection tasks. If this is the initial installation of your communication controller, the following cabling order is recommended:

1. Plug in any Ethernet LAN access unit interface cables.
2. Plug in any high-speed line cables
3. Plug in any token-ring cables.
4. Install cables for the operator console¹, remote support facility², any remote² or alternate² console, and customer power control.
5. Install any line interface couplers or their cables.

Attention

By touching inside the machine, you can cause electrostatic discharges (ESDs) that may result in errors in the system operation, or damage to the equipment. Therefore, it is very important that you touch the ESD plate before you touch any element inside a unit or before you plug in a cable. The ESD plate is located on the inside face of the frame door.

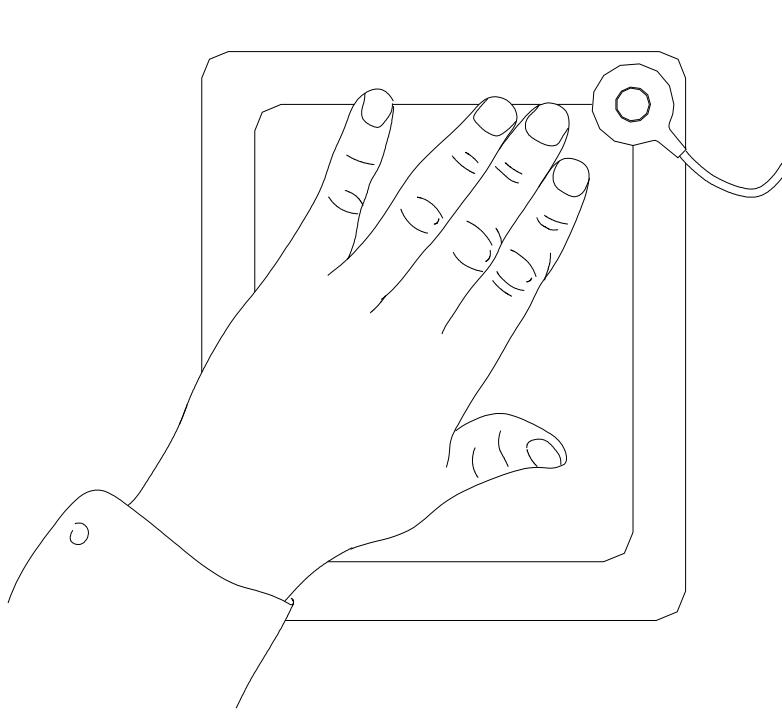

¹ LAN connection to the service processor in case of 3745 Models A.

² This does not apply to the 3745 Models A.

Getting Started

Use this procedure to start all the connection procedures given later in this chapter.

Notes

1. Updating the CDF

In the procedures for the TRA and HSS cables and the LICs there are steps for updating the configuration data file (CDF) and then activating the lines. **If you are connecting several kinds of lines, wait until all of the lines are connected before using the Upgrade or Update procedure.**

For LIC types 5 and 6 integration, refer to the *LIC5/6 Migration and Integration Guide*, SA33-0416 or earlier version of the *Connection and Integration Guide*, SA33-0129.

Do not forget to test the LICs and ask the host operator to activate all affected lines after updating the CDF.

2. Labels

Before the initial installation all external cables from DTEs/DCEs to the 3745 must be labeled. Use the information on the plugging sheets normally stored in the *Preparing for Connection*, GA33-0127, or the *Migration and Planning Guide*, GA33-0183.

Do not forget to add or change the cable labels when you make later modifications.

Step 1 Have the plugging and configuration sheets from the *Migration and Planning Guide*, GA33-0183

Depending on the procedure, you need the plugging and configuration sheets for the:

- Line interface couplers (LICs)
- Line interface coupler (LIC) cables
- Token-ring adapter (TRA) cables
- High-speed scanner (HSS) cables
- Ethernet LAN attachment unit interfaces (AUIs)³
- Operator console cables
- Remote support facility (RSF) cable.

There is no plugging sheets for the customer power control (CPC) cable.

Step 2 Opening the door

Notes:

- The figures below show a 3745 configuration with the maximum number of LIC units available.
- The doors marked with dashed lines are not user-accessible.

³ The AUI is the cable (and its two connectors) that is connected between the Ethernet medium attachment unit (MAU) and the 3745. The MAU is also called the transceiver.

Open the door of the 3745 unit by pushing in and turning the screws (X in this figure) using the special door key.

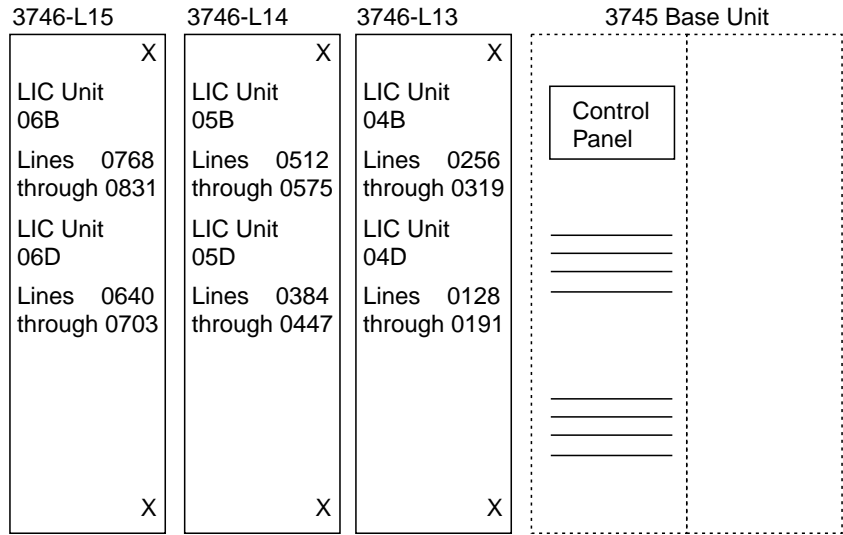

Communication Controller Front View

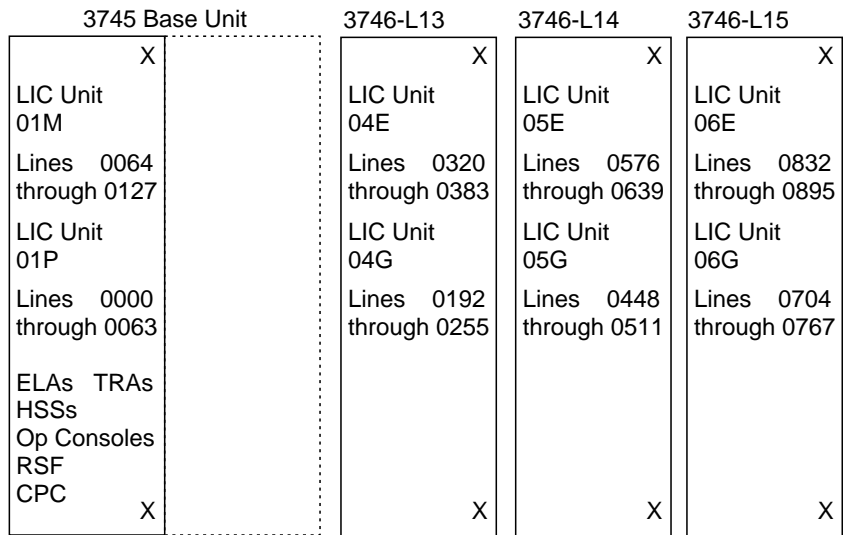

Communication Controller Rear View

If you want to work with the **LICs**, go to “Removing or Installing a Line Interface Coupler (LIC) or Its Cable” on page 1-18.

Otherwise, continue with the next step.

Step 3 Locating non-LIC connectors

Locate the area of the non-LIC connectors. See Figure 1-1.

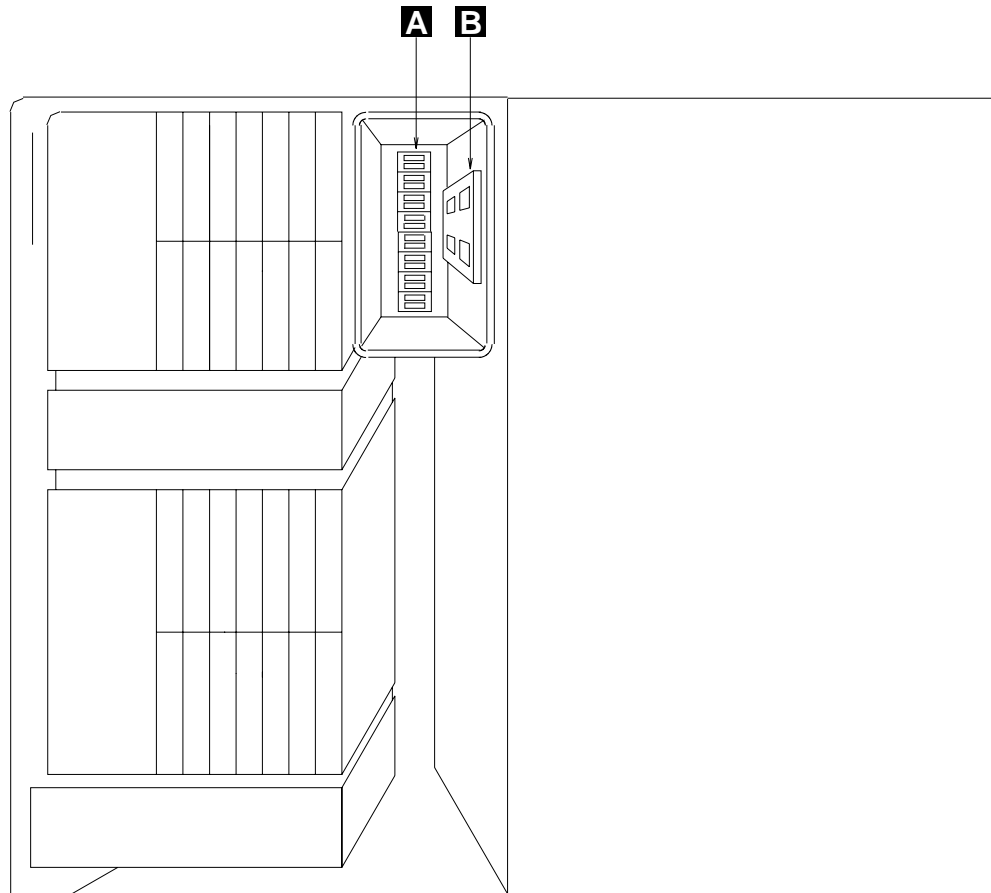

Figure 1-1. 3745 Models 210 to 61A Base Frame Rear View

Area **A** has communication line connectors for:

- High-speed scanners
- Token-ring adapters
- Ethernet LAN adapters.

Area **B** has the service cables connectors for:

- Local operator console (not for Models A)
- LAN connection to the service processor (Models A only)
- Remote/Alternate operator console (not for Models A)
- Remote support facility (RSF) console (not for Models A)
- Customer power control (CPC).

Locate the connector using the Figure 1-3 on page 1-6 and Figure 1-4 on page 1-7. If the connectors you need are located in the area **B**, go to Step 6 on page 1-6

Otherwise, continue with the next step.

Step 4 Locating the communication adapter connector

Locate the individual connector in area **A**, (Figure 1-1 on page 1-4) for every cable to be plugged-in or unplugged. Figure 1-2 shows four possible example configurations (that are fully populated):

- 1** All HSSs
- 2** All ELAs
- 3** Four TRAs with four HSSs
- 4** Four TRAs with four ELAs.

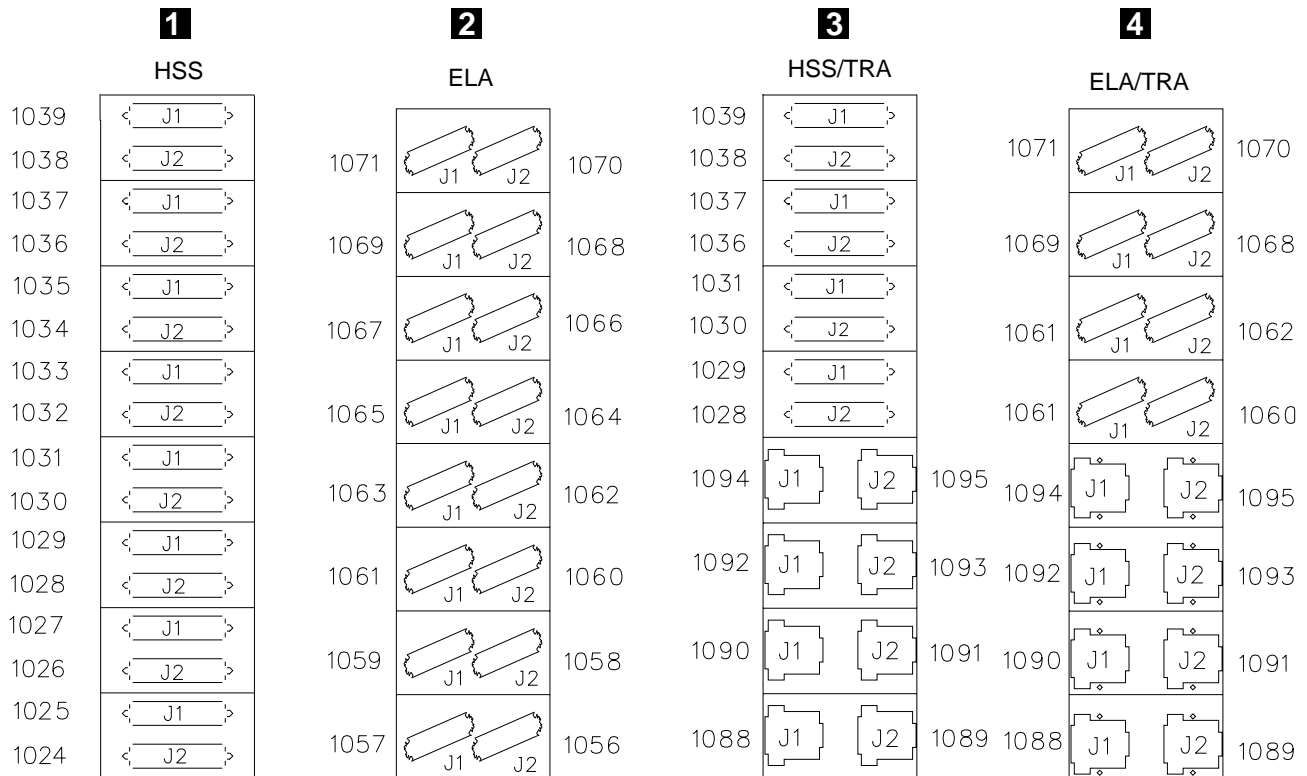

Figure 1-2. Four Possible Configurations of Area A

The numbers are the line numbers of the connectors. Your 3745 may not be exactly the same: it may not be fully populated and may have a different mixture of communication lines.

Step 5 Deactivating the lines

If you are disconnecting any line (by **removing** a cable), ask the host operator to deactivate all the lines to be unplugged.

Note: The line number is the same as the port number.

Then go to the following sections as needed:

- “Unplugging or Plugging In an Ethernet LAN AUI Cable” on page 1-7
- “Unplugging or Plugging In a Token-Ring Adapter (TRA) Cable” on page 1-11

- “Unplugging or Plugging In a High-Speed Scanner (HSS) Cable” on page 1-13.

Step 6 Locating the service connectors

The area **B**, (Figure 1-1 on page 1-4) contains the connectors for:

- Local operator console (not for Models A)
- LAN connection to the service processor (Models A only)
- Remote/alternate operator console (not for Models A)
- RSF console (not for Models A)
- Customer power control (CPC).

Locate the connector using the Figure 1-3 and Figure 1-4 on page 1-7.

When you have located the connector, go to the following sections as needed:

- “Unplugging or Plugging In an Operator Console Cable” on page 1-15
- “Unplugging or Plugging In the Remote Support Facility (RSF) Cable” on page 1-16
- “Removing or Installing the Customer Power Control (CPC) Cable” on page 1-18.

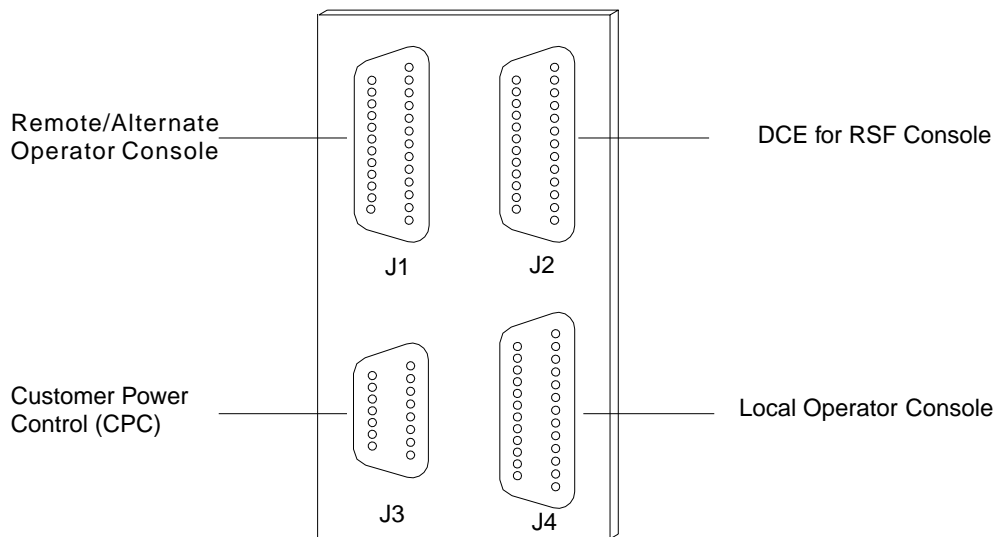

Figure 1-3. 3745 Models 210 to 610: Service Connectors

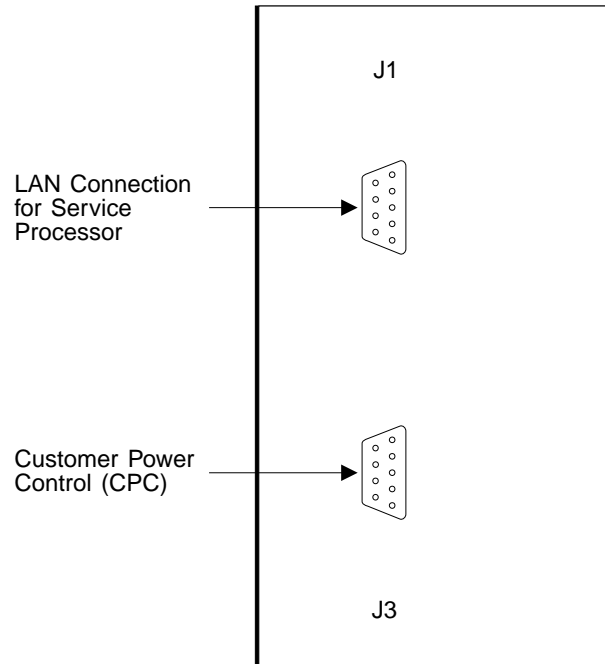

Figure 1-4. 3745 Models 21A to 61A: Service Connectors

Unplugging or Plugging In an Ethernet LAN AUI Cable

IMPORTANT

Install only AUI cables that conform to ISO 8802-3.

The ISO 8802-3 says:

"The connector is not specified to prevent operator contact with the shield, precautions shall be taken at installation time to ensure that the installer is warned that the shield is not brought into contact with any hazardous voltage while being handled by operating personnel."

ATTENTION

To attach your communication controller to the Ethernet LAN, the SQE TEST switch on the MAU must be set to ENABLE. If this is not done when you connect the AUI to the 3745, operation of the Ethernet LAN may be interrupted.

Step 1 Starting

Before beginning, you must first do the procedure "Getting Started" on page 1-2.

There is a locking latch attached to the 3745 ELA connector. It is hard to see as it is between the cable connector and the 3745. In this procedure you may have to depend on feeling the latch with your fingertips rather than seeing it. It is sometimes hard to move, you may need to try more than once.

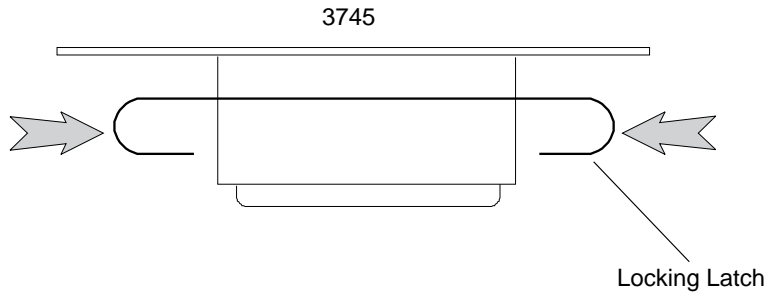

If you are **only plugging in** an AUI cable, go to Step 3 on page 1-9
Otherwise, continue with the next step.

Step 2 Unplugging an AUI cable.

Repeat this step for every AUI to be unplugged.

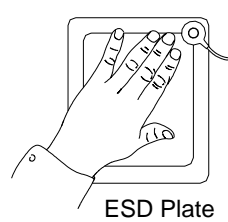

1. Unlock the latch by pushing it to the right (the open padlock position). It may require a lot of force to move it.

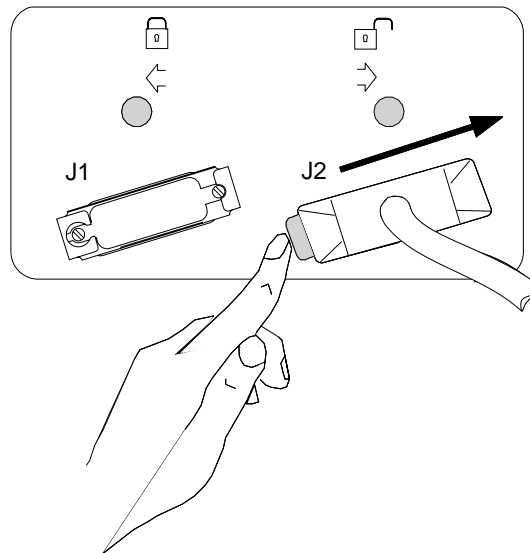

2. Pull out the plug.

If you are **not plugging in** an AUI, go to Step 6 on page 1-11.
Otherwise, continue with the next step.

Step 3 Plugging in an AUI cable

Repeat this step for every AUI to be plugged in.

Note: Make sure that all the cables are correctly labeled at both ends before doing this step.

1. Locate a cable with a label. Find the port that matches the cable.

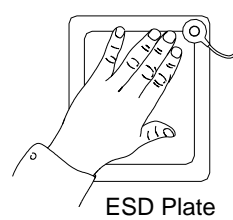

2. Slide the latch to the right (the open padlock position).

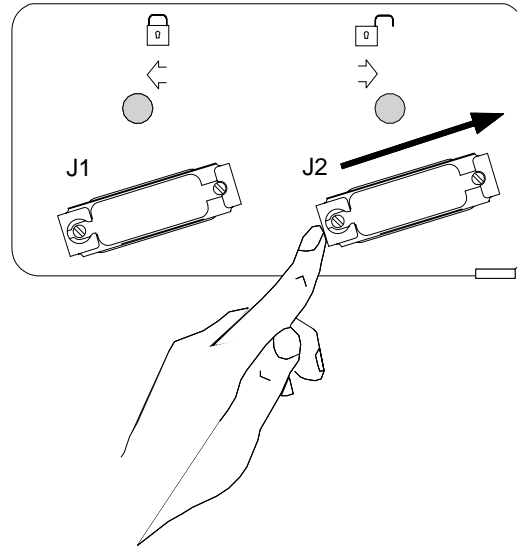

3. Hold the cable connector so that its longest side is downward.

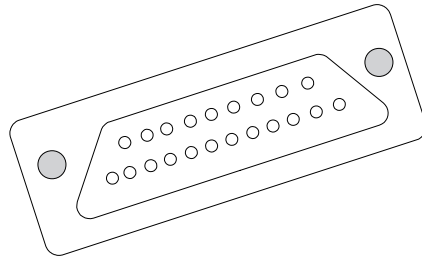

4. Push the plug strongly into the port connector.

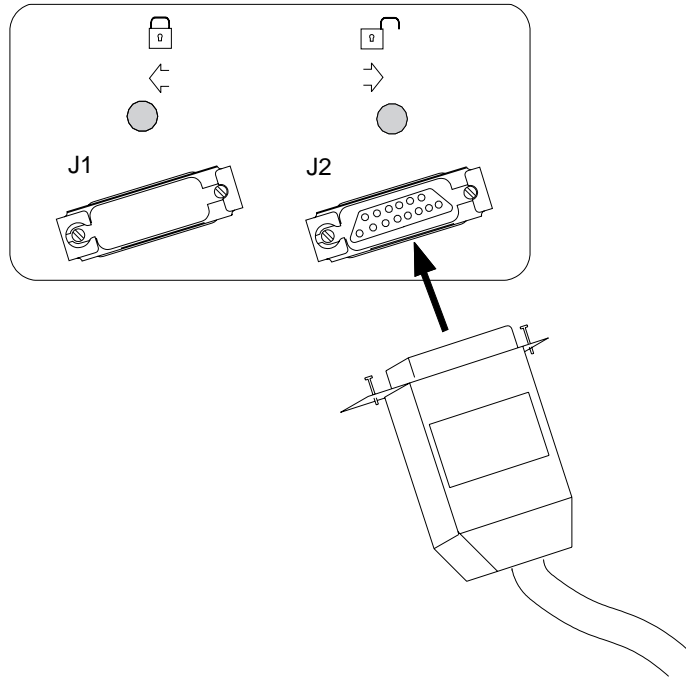

5. Push the locking latch to the left to lock it (the closed padlock position). It may require a lot of force to move it.

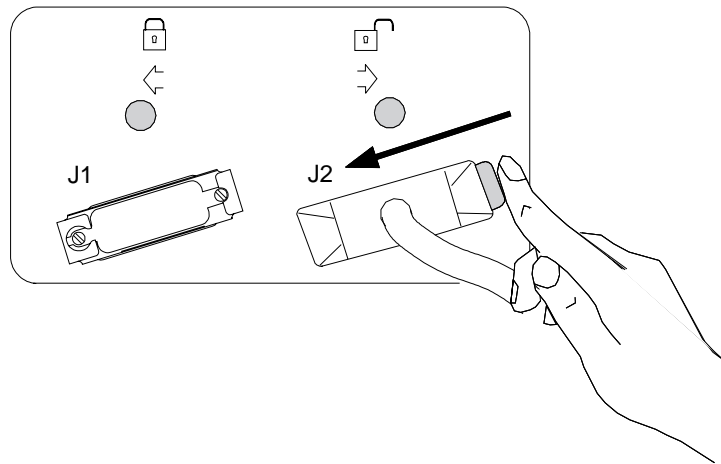

6. To check that the cable is locked in place, move the cable connector from side-to-side while trying to pull it out of the 3745 ELA connector. **Do not jerk** on the cable.

Step 4 Routing cable

You may use the magnetic clamp that came with your Ethernet adapter to secure and separate the AUJ cables from the other cables if your machine becomes too crowded with cables.

Magnetic Cable Clamp

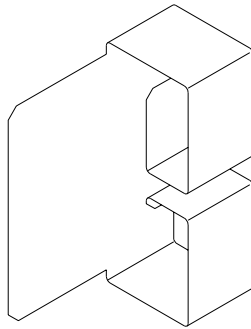

Extra Clamps are Available on Request.
Please Contact your IBM Service Representative.
The Part Number is 26F1775.

Step 5 Activating the lines

Ask the host operator to activate any lines plugged in.

Notes:

- a. The line number is the same as the port number.
- b. If you have installed a link-attached 3745, make sure that the link IPL port cables are connected before attempting an IPL.

Step 6 You have finished this procedure

Close and lock the door using the special door key.

Unplugging or Plugging In a Token-Ring Adapter (TRA) Cable

If you have a 3745 Model A without a 3746-900 attached

Do not use this procedure to make changes to the cable that connects the 3745 to the token-ring LAN used by the service processor. These are IBM service representative tasks.

Step 1 Starting

If you have not done the procedure "Getting Started" on page 1-2, do so now.

If you are **only plugging in** TRA cable, go to Step 3 on page 1-12

Otherwise, continue with the next step.

Step 2 Unplugging a TRA cable.

Repeat this step for every TRA cable to be unplugged.

1. Remove the cable by squeezing the levers and pulling out the plug.
2. Replace the protective cap on the cable plug.

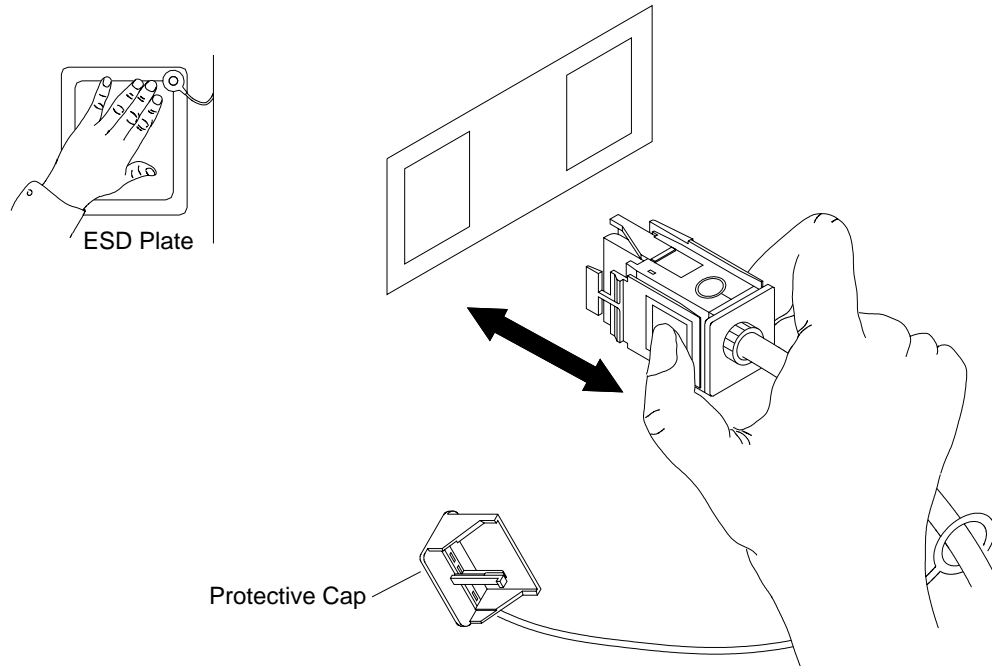

If you are **not plugging in** a TRA cable, go to Step 6 on page 1-13. Otherwise, continue with the next step.

Step 3 Plugging in a TRA cable.

Repeat this step for every TRA cable to be plugged in.

Note: Make sure that all the cables are correctly labeled at both ends before doing this step.

- a. Refer to the figure of the Step 2.
- b. Locate the cable with a label that matches its port number.
- c. Remove the protective cap from the cable plug.
- d. Hold this plug with the levers on the sides, squeeze both levers, and push the plug strongly into the port.

Step 4 Upgrade CDF

You must perform the Upgrade procedure in “Upgrading or Updating CDF” on page 5-7. You can either do it now and continue with the next step or later when you have finished all your connection procedures.

Step 5 Activating the lines

Ask the host operator to activate any lines that were plugged in.

Note: The line number is the same as the port number.

Step 6 You have finished this procedure

If you have no other connection procedures to do, close and lock the door using the special door key.

Unplugging or Plugging In a High-Speed Scanner (HSS) Cable

Step 1 Starting

If you have not done the procedure “Getting Started” on page 1-2, do so now.

If you are **only plugging in** HSS cables, go to Step 3 on page 1-14

Otherwise, continue with the next step.

Step 2 Unplugging an HSS cable

Remove the cable by squeezing the levers and pulling out the plug.

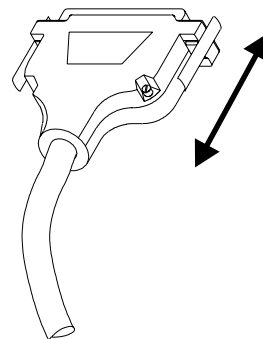
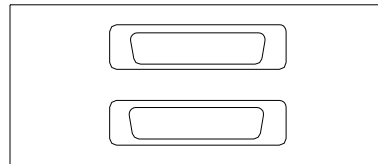
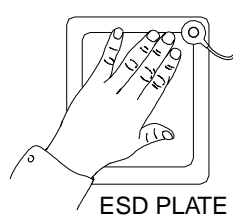

Repeat this step for every HSS cable to be unplugged.

If you are **not plugging in** an HSS cable, go to Step 4 on page 1-14

Otherwise, continue with the next step.

Step 3 Plugging in an HSS cable.

Repeat this step for every HSS cable to be plugged in.

Note:

- Make sure that all the cables are correctly labeled at both ends before doing this step.
 - If you connect the HSS to a DTE equipment (such as IBM 2210 router), for allowing RLSD signal propagation, the DCE side of the cable must be connected to the HSS and the DCE side to the router.
- a. Refer to the figure of the Step 2 on page 1-13.
 - b. Locate the cable with a label that matches its port number.
 - c. Take the plug of one cable, squeeze the side levers, and push the plug strongly into the corresponding port in your unit.

Step 4 Upgrade CDF

You must perform the Upgrade procedure in “Upgrading or Updating CDF” on page 5-7. You can either do it now and continue with the next step or later when you have finished all your connection procedures.

Step 5 Activating the lines

Ask the host operator to activate any lines plugged in.

Notes:

- a. The line number is the same as the port number.
- b. If you have installed a link-attached 3745, make sure that the link IPL port cables are connected before attempting an IPL.

Step 6 You have finished this procedure

If you have no other connection procedures to do, close and lock the door using the special door key.

Unplugging or Plugging In an Operator Console Cable

Note: This procedure applies to both local and alternate/remote cables connected to J1 and J4 (see Figure 1-3 on page 1-6).

Attention

This procedure does not apply for Models A.

Step 1 Starting

If you have not done the procedure “Getting Started” on page 1-2, do so now.

Ask the host operator to log off at the application console.

If you are **only plugging in** an operator console cable, go to Step 3 on page 1-16.

Otherwise, continue with the next step.

Step 2 Unplugging an operator console cable

- a. Unfasten the ground cable clamp. This cable clamp is fixed on the bottom of the frame in one of the three holes.

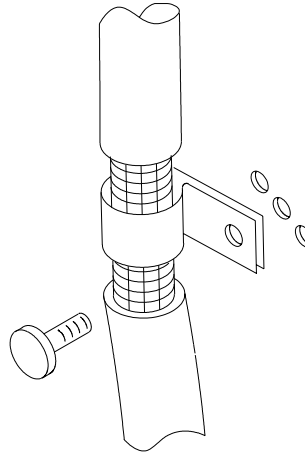

- b. Remove the cable by squeezing the levers and pulling out the plug.

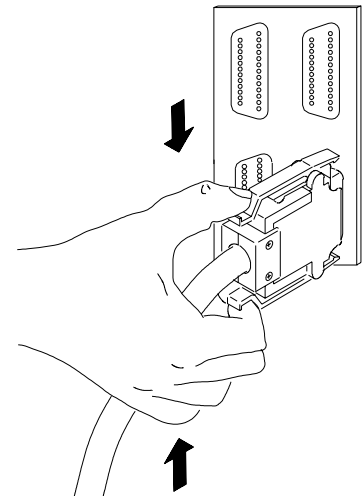
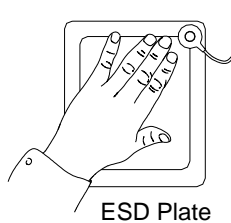

Repeat this step for every operator console cable to be unplugged.

If you are **only unplugging** an operator console cable, go to Step 5.

Step 3 Plugging in an operator console cable

- a. Refer to the figures of the Step 2 on page 1-15.
- b. Find the cable with a label that matches the connector.
- c. Fasten the ground cable to the frame with the cable clamp. This cable clamp is fixed on the bottom of the frame in one of the three holes.

Note: The ground cable clamp serves to reduce the possibility of radio frequency interference that might be caused by the operating machine. Proper installation of the cable clamp is necessary to meet FCC requirements, and to conduct electrostatic discharges (ESDs) to ground.

- d. Hold the plug of the cable with the green side lever upward, squeeze both side levers, and push the plug strongly into the connector.

Repeat this step for every operator console cable to be plugged in.

Step 4 Host log on

The operator may now log on to the application console.

Step 5 You have finished this procedure

If you have no other connection procedures to do, close the door using the special door key.

Unplugging or Plugging In the Remote Support Facility (RSF) Cable

See Figure 1-3 on page 1-6 to locate this cable.

Attention

This procedure does not apply for Models A.

Step 1 Starting

If you have not done the procedure "Getting Started" on page 1-2, do so now.

If you are **only plugging in** the RSF cable, go to Step 3 on page 1-17.

Otherwise, continue with the next step.

Step 2 Unplugging the DCE cable for RSF

- a. Unfasten the ground cable clamp. This cable clamp is fixed on the bottom of the frame in one of the three holes.

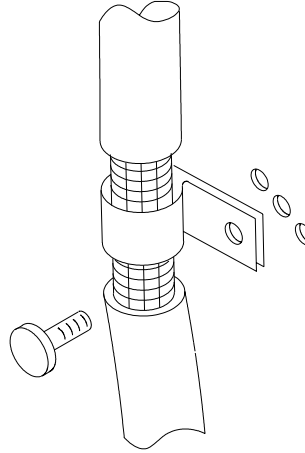

- b. Remove the cable by squeezing the levers and pulling out the plug.

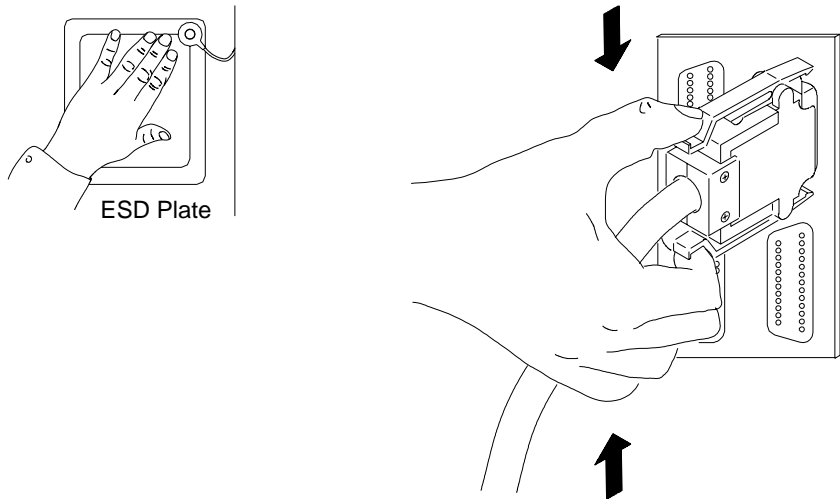

If you are **only unplugging** the RSF cable, go to Step 4 on page 1-18.

Step 3 Plugging in the DCE cable for RSF

- a. Refer to the figures of the Step 2.
- b. Find the cable with a label that matches the connector.
- c. Fasten the ground cable to the frame with the cable clamp. This cable clamp is fixed on the bottom of the frame in one of the three holes.

Note: The cable clamp serves to reduce the possibility of radio frequency interference that might be caused by the operating machine. Proper installation of the cable clamp is necessary to meet FCC requirements, and to conduct electrostatic discharges (ESDs) to ground.

- d. Hold the plug of the cable with the green side lever upward, squeeze both side levers, and push the plug strongly into the port connector.

Step 4 You have finished this procedure

If you have no other connection procedures to do, close and lock the door using the special door key.

Removing or Installing the Customer Power Control (CPC) Cable

Note: The CPC cable and connector are not provided by IBM, and, therefore, are not shown here; neither are given the details of securing the CPC cable in place.

Step 1 Starting

If you have not done the procedure “Getting Started” on page 1-2, do so now.

If you are **only plugging in** the CPC cable, go to Step 3.

Otherwise, continue with the next step.

Step 2 Unplugging the CPC cable

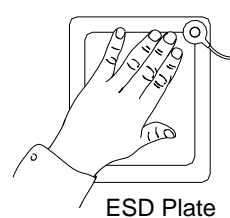

Remove CPC cable from CPC connector. See Figure 1-3 on page 1-6 or Figure 1-4 on page 1-7.

If you are **not plugging in** the CPC cable, go to Step 4.

Step 3 Plugging in the CPC cable

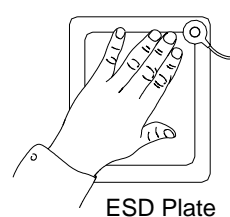

1. Find the cable with a label that matches the connector.
2. Install the cable into the CPC connector.

Step 4 You have finished this procedure

If you have no other connection procedures to do, close and lock the door using the special door key.

Removing or Installing a Line Interface Coupler (LIC) or Its Cable

For LIC types 5 and 6, refer to the *LIC5/6 Migration and Integration Guide*, SA33-0416 or earlier version of the *Connection and Integration Guide*, SA33-0129.

LIC Slots: Regardless of the number of ports (lines) that are actually used, four line numbers are allocated for each LIC slot in an LIU1. These slots hold LIC types 1, 3, and 4.

Line Weights: When reconfiguring LICs, ensure that the total weight of lines connected to a low-speed scanner is within the scanner maximum capacity. To calculate them see Appendix A, "LSS Characteristics and Line Weights."

Step 1 Starting

If you have not done Steps 1 and 2 of the procedure "Getting Started" on page 1-2, do so now.

Step 2 Locating the LIC slot

Use the LIU tables on the inner surface of the open unit door. Following are schematic representations of the possible locations of LICs and their line numbers within the unit you have opened.

The following tables are for an LIU1 (LIC types 1, 3, and 4).

	D	E	F	G	H	J	K	L	
P O R T S	0	096	100	104	108	112	116	120	124
	1	097	101	105	109	113	117	121	125
	2	098	102	106	110	114	118	122	126
	3	099	103	107	111	115	119	123	127

For example, **112** is the number of port 0 for the LIC in slot H (in the upper half of the upper LIU 1 of the 3745 base frame unit).

	D	E	F	G	H	J	K	L	
P O R T S									
	DCE	096	100	104	108	112	116	120	124
	DTE	096	100	104	108	112	116	120	124

LIC 3s have only one port but two types of connectors: DCE (modem) or DTE (direct attachment).

For LUI2 (LIC types 5 and 6), refer to the *LIC5/6 Migration and Integration Guide*, SA33-0416 or earlier version of the *Connection and Integration Guide*, SA33-0129.

Repeat this step for every LIC to be inserted or removed.

If you are **only installing a LIC**, go to Step 4 on page 1-20.

If you are **only plugging in a LIC cable**, go to Step 8 on page 1-22.

Otherwise, continue with the next step.

Step 3 Deactivating line

Ask the host operator to deactivate all the lines connected to the LIC you want to work with.

Attention

Deactivation of all the lines of the LIC is necessary to prevent problems at line adapter restart.

The line number is the same as the LIC port number.

For LIC types 1, 3, and 4:

There are up to four lines per LIC.

For LIC types 5 and 6:

Refer to the *LIC5/6 Migration and Integration Guide*, SA33-0416 or earlier version of the *Connection and Integration Guide*, SA33-0129.

Step 4 Identifying LIC

LICs are not labeled. To identify a LIC, make a visual inspection.

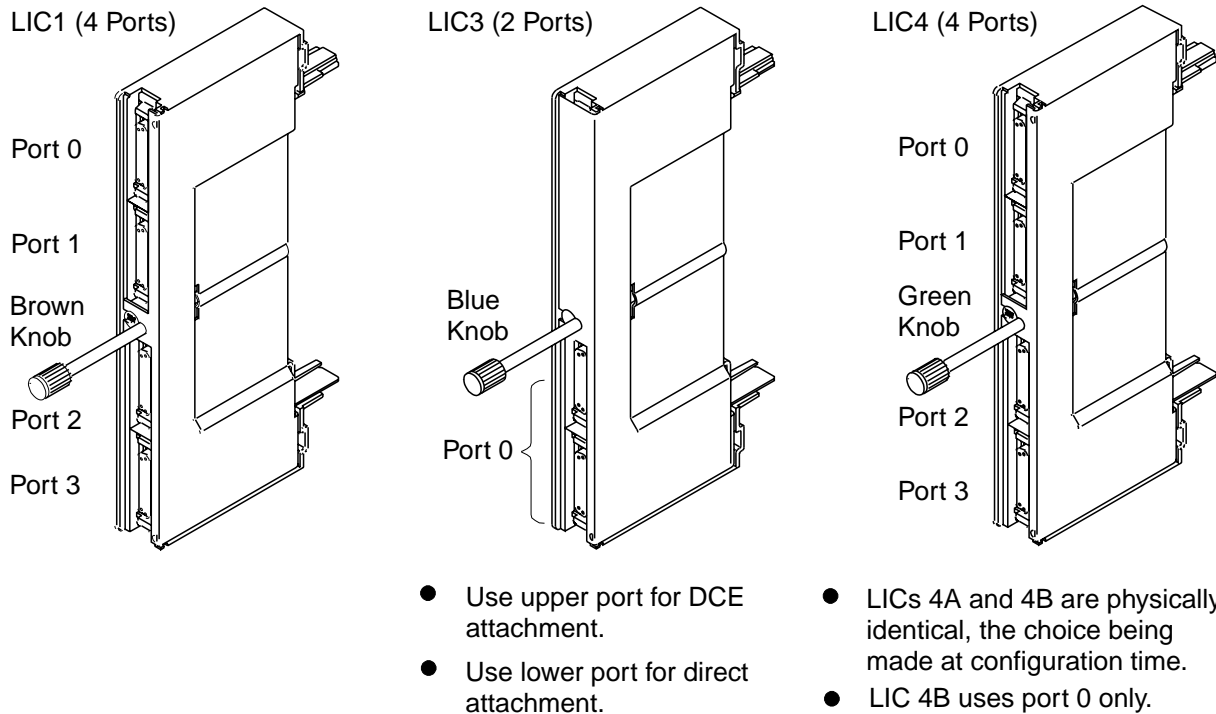
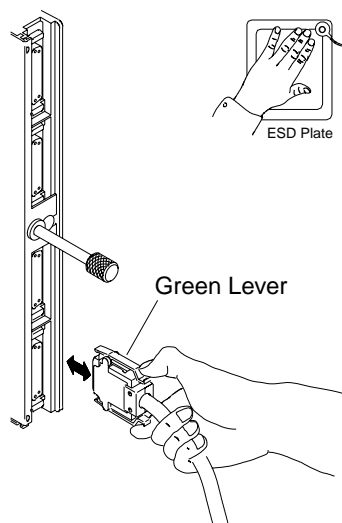

Figure 1-5. LIC Types 1, 3, and 4.

Step 5 Unplugging LIC cable

Repeat this step for every LIC cable to be removed.

Unplugging LIC types 1, 3, and 4 Cable



Remove the cable by squeezing the side levers and pulling out the plug.

Unplugging LIC types 5 and 6 Cable

Refer to the *LIC5/6 Migration and Integration Guide*, SA33-0416 or earlier version of the *Connection and Integration Guide*, SA33-0129.

If you are **only unplugging** a LIC cable, go to Step 10 on page 1-25.

If you are **only plugging in** LIC cable without removing LIC, go to Step 8 on page 1-22.

Otherwise, **to remove LIC**, continue with the next step.

Step 6 Removing LIC

Repeat this step for every LIC to be removed.

- a. Turn the knob counterclockwise to unlock the LIC.
- b. Remove the LIC by delicately pulling it out.

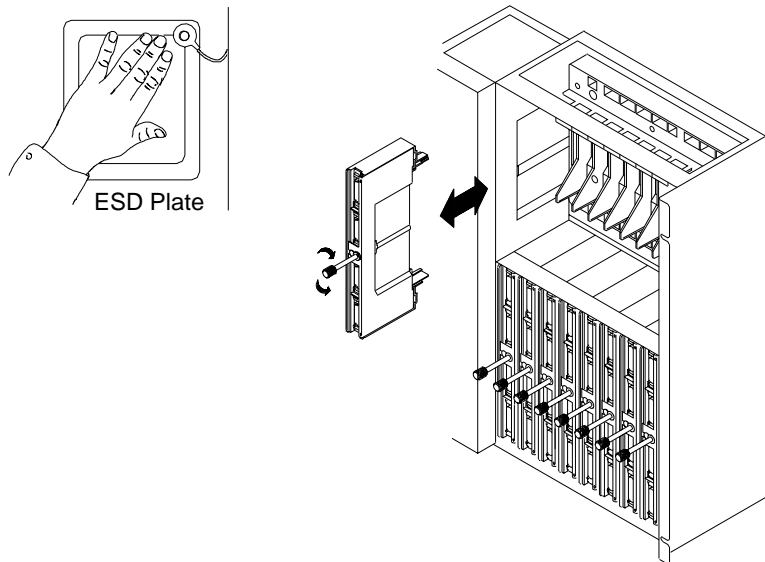

If you have **no LICs to install**, go to Step 10 on page 1-25.

Otherwise, continue with the next step.

Step 7 Inserting LIC

- a. Ensure that the slot is clear. If necessary, carefully remove the bundle of cables for this LIC row from behind the cable retaining bracket (Do not forget to replace the cables behind the retaining bracket when finished).
- b. Hold the LIC so that the black plastic side is on the left and the knob is pointing toward you.
- c. Push the LIC into the slot until it clicks.
- d. Turn the knob clockwise to lock the LIC in place.

For LIC types 5 and 6, refer to the *LIC5/6 Migration and Integration Guide*, SA33-0416 or earlier version of the *Connection and Integration Guide*, SA33-0129.

Step 8 Plugging in LIC cable

At initial installation, the following order is recommended:

- 1** 3745 Base or 3746 Expansion Unit.
Start with the Top Row of LICs and
Work Towards the Bottom:

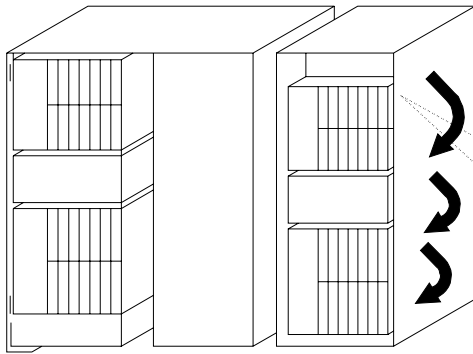

- 2** LIC Unit.
Start with the Right-Hand LIC and
Work Towards the Left:

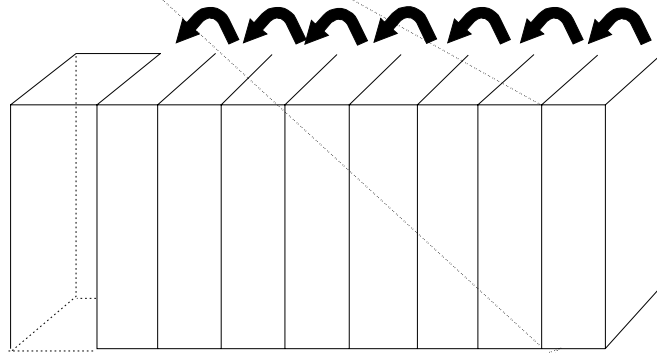

- 3** LIC.
Start with the Lower Connector of a LIC and
Work Towards the Top:

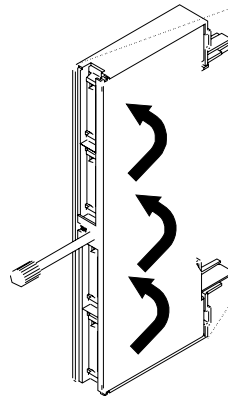

Make sure that all the cables are correctly labeled at both ends before doing this step.

Repeat this step for every LIC cable installed.

Plugging In LIC Type 1, 3, and 4 Cable

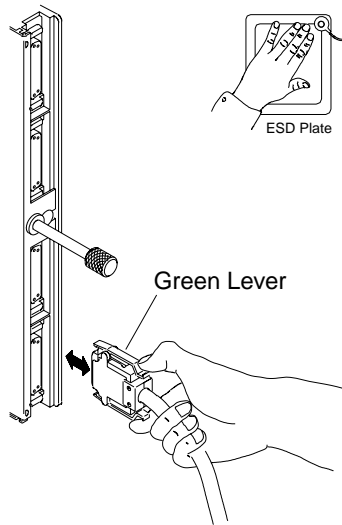

1. Locate the cable with a label that matches the information on the plugging sheet for the lower port of the LIC.
2. Hold the plug of the cable with the green lever upward, squeeze both side levers, and push the plug strongly into the port.
3. Plug in all lower cables, then continue with the upper cables.

Attention

For LIC types 3 and 4B, only one cable must be connected

Plugging In LIC Types 5 and 6 Cables

Refer to the *LIC5/6 Migration and Integration Guide*, SA33-0416 or earlier version of the *Connection and Integration Guide*, SA33-0129.

Step 9 Routing cable

Ensure that all the cables are neatly arranged and well secured. You can use magnetic clamps to separate and neatly arrange the different types of cables. For a drawing of the clamp, see Figure 1-6.

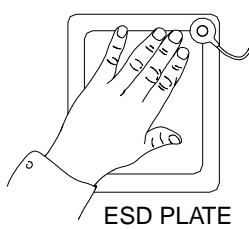

3745 Base Frame

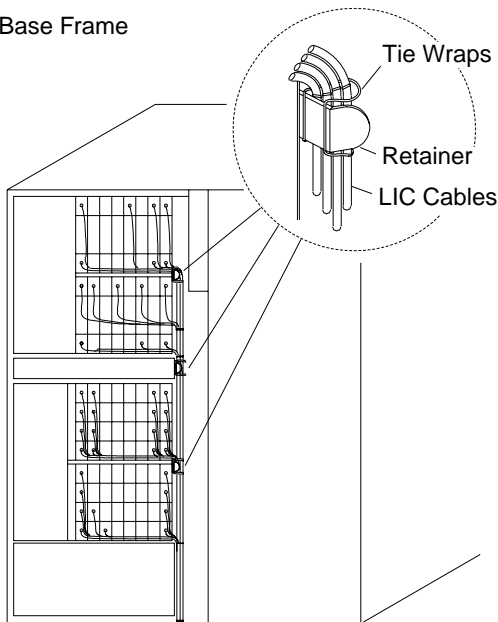

3746-L1x

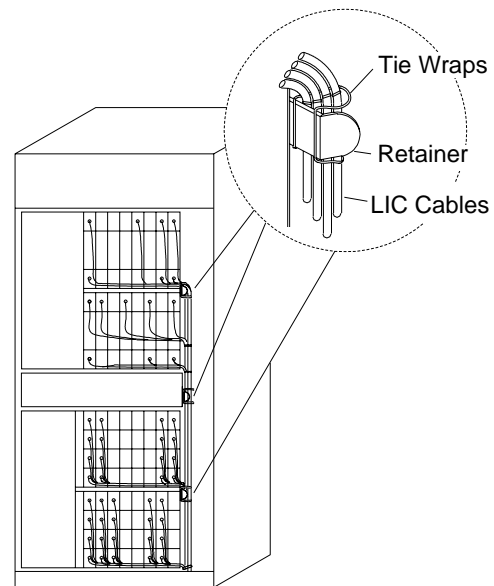

Magnetic Cable Clamp

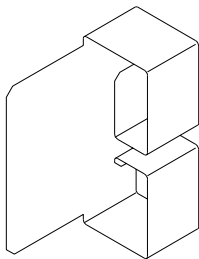

If many cables are to be installed, use the magnetic cable clamps. These clamps are available on request. Please contact your IBM service representative. The part number is 26F1775.

Figure 1-6. 3745 Cable Arrangement

- If you are **only installing or replacing a LIC type 1, 3, or 4**, go to the next step.
- If you are **only replacing a LIC cable**, go to Step 13 on page 1-25.

Step 10 Updating the CDF

Go to “Upgrading or Updating CDF” on page 5-7 and perform the steps as instructed. Then:

- If you are **only installing or replacing a LIC type 1, 3, or 4**, go to the next step.
- If you are **only installing a new LIC type 1, 3, or 4 cable**, go to Step 13
- If you are **only replacing a LIC type 1, 3, or 4 cable**, go to the next step.

Step 11 Testing a LIC type 1, 3, or 4

Refer to the wrap test (WTT) function in the *Advanced Operations Guide*, SA33-0097 and perform the automatic wrap test at the LIC level. NCP must be loaded to run WTT.

If you have installed more than one LIC or LIC cable, repeat this step for each one installed.

Otherwise, continue with the next step.

Step 12 Configuring the LIC 5 and 6 Modems

Refer to the *LIC5/6 Migration and Integration Guide*, SA33-0416 or earlier version of the *Connection and Integration Guide*, SA33-0129.

Step 13 Activating the lines

Ask the host operator to activate the line of all newly installed LIC or LIC cable.

Attention

If one of the affected lines was not deactivated at Step 3 on page 1-19, you may be forced to re-load the NCP.

Step 14 You have finished this procedure

Do no more steps. If you have no other connection procedures to do, close and lock the door using the special door key.

Chapter 2. 3745 Models 130 to 17A: Connecting LICs and Cables

This chapter gives all the procedures for the 3745 (Models 130, 150, 160,170, and 17A) hardware connection task. If this is the initial installation of your communication controller, the following cabling order is recommended:

1. Plug in any Ethernet LAN access unit interface cables
2. Plug in any high-speed line cables
3. Plug in any token-ring cables
4. Install the operator console(s)¹, remote support facility², any remote² or alternate² console, and customer power control cables.
5. Install any line interface couplers or their cables.

Attention

By touching inside the machine, you can cause electrostatic discharges (ESDs) that may result in errors in the system operation, or damage to the equipment. Therefore, it is very important that you touch the ESD plate before you touch any element inside a unit or plug in a cable. The ESD plate is located on the inside face of the frame door.

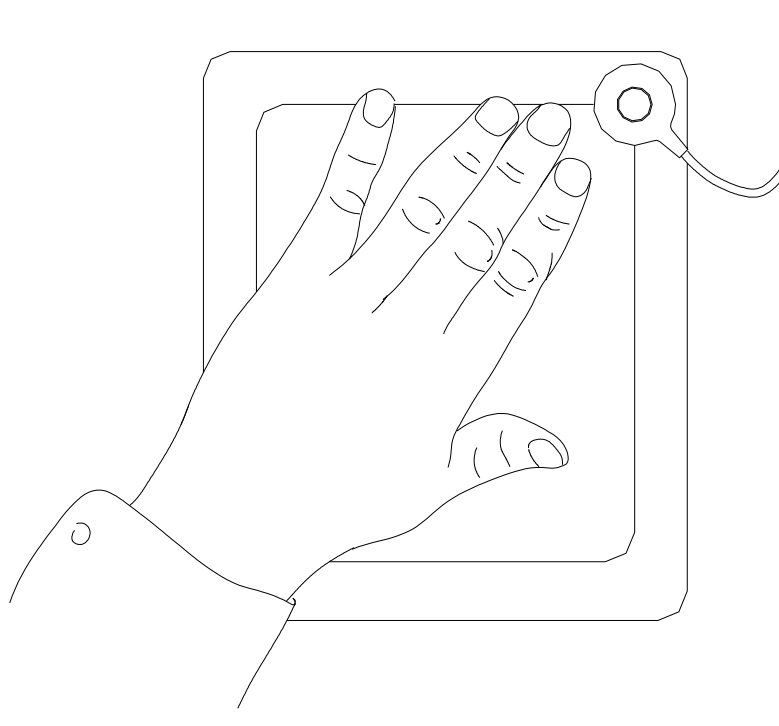

¹ LAN connection to the service processor in case of 3745 Model 17A.

² This does not apply to the 3745 Model 17A.

Getting Started

Use this procedure to start all connection procedures given later in this chapter.

Notes

1. Updating the CDF

In the procedures for the TRA and HSS cables and the LICs there are steps for updating the configuration data file (CDF) and then activating the lines. **If you are connecting several kinds of lines, wait until all of the lines are connected before using the Upgrade or Update procedure.**

For LIC type 5 and 6 integration, refer to the *LIC5/6 Migration and Integration Guide*, SA33-0416 or earlier version of the *Connection and Integration Guide*, SA33-0129.

Do not forget to test the LICs and ask to host operator to activate all affected lines after updating the CDF.

2. Labels

Before the initial installation all external cables from DTEs/DCEs to the 3745 must be labeled. Use the information on the plugging sheets normally stored in the *Preparing for Connection*, GA33-0140, or the *Migration and Planning Guide*, GA33-0183.

Do not forget to add or change the cable labels when you make modifications.

Step 1 Have the plugging and configuration sheets from the *Migration and Planning Guide*, GA33-0183.

Depending on the procedure(s), you need the plugging and configuration sheets for the:

- Line interface couplers (LICs)
- Line interface coupler (LIC) cables
- Token-ring adapter (TRA) cables
- High-speed scanner (HSS) cables
- Ethernet LAN attachment unit interfaces (AUIs)³
- Operator console cables
- Remote support facility (RSF) cable.

There is no plugging sheets for the customer power control (CPC) cable.

Step 2 Opening the door

Open the rear door of the 3745 unit by pushing in and turning the screws using the special door key.

If you want to work with the **LICs**, go to “Removing or Installing a Line Interface Coupler (LIC) or Its Cable” on page 2-13.

³ The AUI is the cable (and its two connectors) that is connected between the Ethernet medium attachment unit (MAU) and the 3745. The MAU is also called the transceiver.

Otherwise, continue with the next step.

Step 3 Locating communication line and service connectors

Locate the area of non-LIC connectors, that is communication line and service connectors. See Figure 2-1.

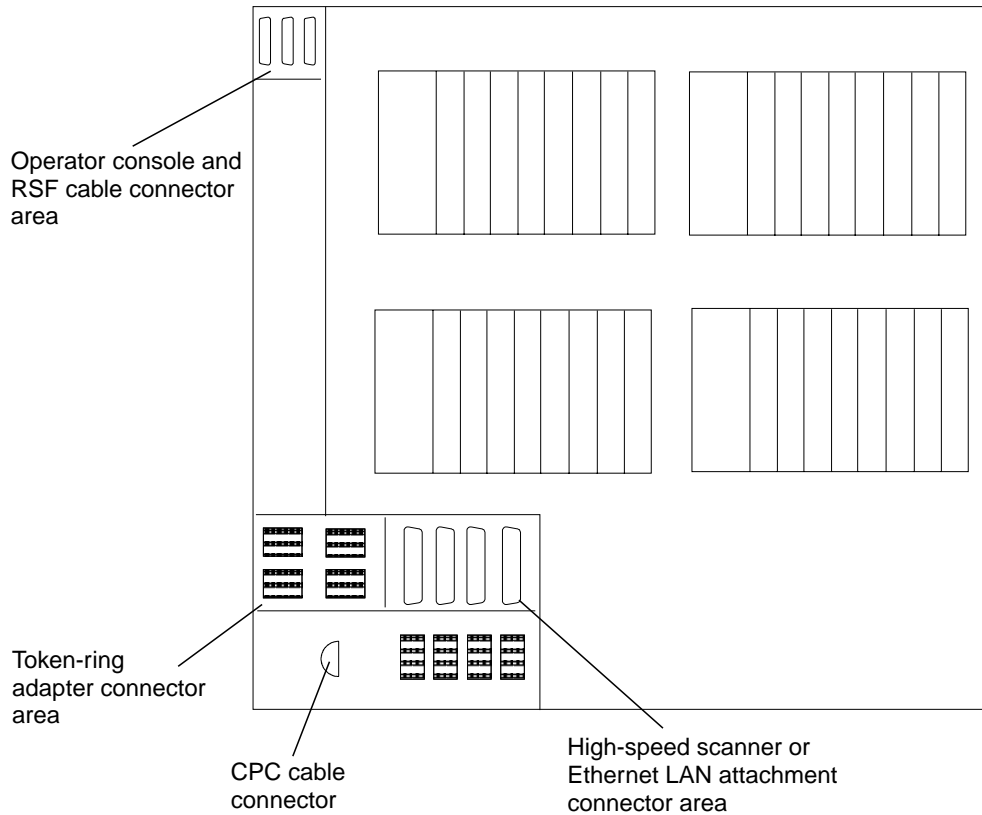

Figure 2-1. Non-LIC Connector Location

If you have a 3745 Model 17A

You have only the customer power control (CPC) connector available for user access.

You do not have connectors for the operator console and for the remote support facility (RSF) console.

Installing or changing the service processor or cable is an IBM service representative task.

When you have located the connector(s), go to the following sections as needed:

- “Unplugging or Plugging In an Operator Console Cable” on page 2-9
- “Unplugging or Plugging In the Remote Support Facility (RSF) Cable” on page 2-11
- “Removing or Installing the Customer Power Control (CPC) Cable” on page 2-12.

For communication lines, continue with the next step.

Step 4 Deactivating lines

If you are disconnecting any line (by **removing** a cable), ask the host operator to deactivate all the lines to be unplugged.

Note: The line number is the same as the port number.

Then go to the following sections as needed:

- “Unplugging or Plugging In an Ethernet LAN AUI Cable”
- “Unplugging or Plugging In a Token-Ring Adapter (TRA) Cable” on page 2-7
- “Unplugging or Plugging In a High-Speed Scanner (HSS) Cable” on page 2-8.

Unplugging or Plugging In an Ethernet LAN AUI Cable

IMPORTANT

Install only AUI cables that conform to ISO 8802-3.

The ISO 8802-3 says:

“The connector is not specified to prevent operator contact with the shield, precautions shall be taken at installation time to ensure that the installer is warned that the shield is not brought into contact with any hazardous voltage while being handled by operating personnel.”

ATTENTION

To attach your controller to the Ethernet LAN, the SQE TEST switch on the MAU must be set to ENABLE. If this is not done when you connect the AUI to the 3745, operation of the Ethernet LAN may be interrupted.

Step 1 Starting

Before beginning, you must first do the procedure “Getting Started” on page 2-2.

There is a locking latch attached to the 3745 ELA connector. It is hard to see as it is between the cable connector and the 3745. In this procedure you may have to depend on feeling the latch with your fingertips rather than seeing it. It is sometimes hard to move, you may need to try more than once.

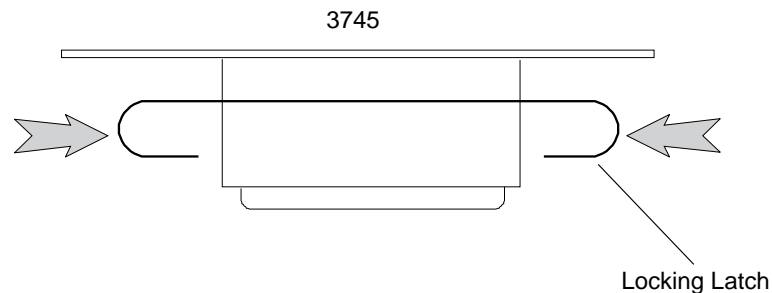

If you are only plugging in AUI cable(s), go to Step 3 on page 2-6. Otherwise continue with the next step.

Step 2 Unplugging an AUI cable

Repeat this step for every AUI cable to be unplugged.

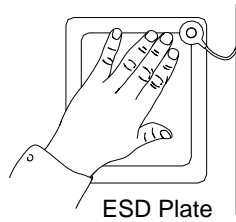

1. Locate the port.

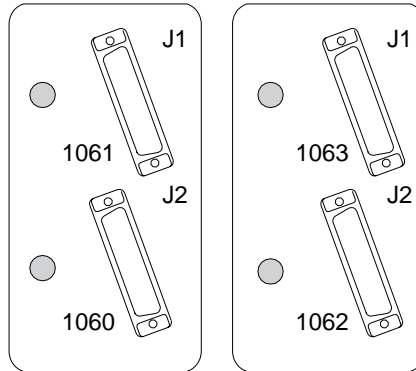

2. Unlock the cable by sliding the latch upwards and to the left (the open padlock position). It may require a lot of force to move it.

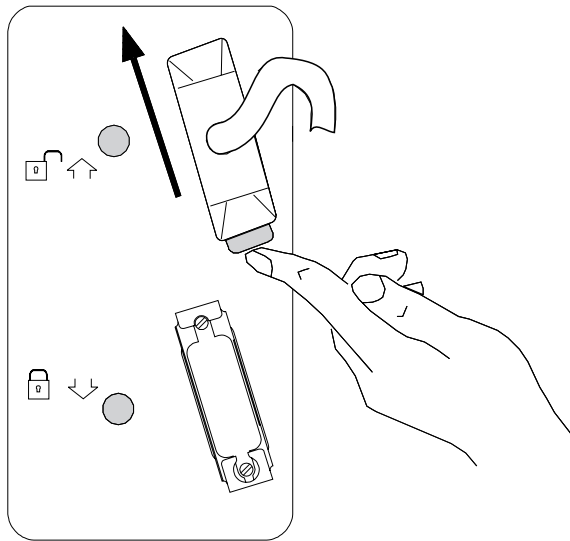

3. Pull out the plug.

If you are going to plug in a new cable, continue with the next step. Otherwise, go to Step 5 on page 2-7.

Step 3 Plugging in an AUI cable

Repeat this step for every cable to be plugged in.

1. Locate the cable by the port number written on the label.
2. Touch the electrostatic discharge plate.

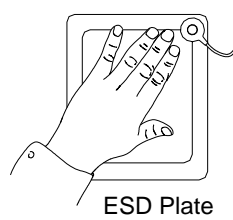

3. Locate the port.

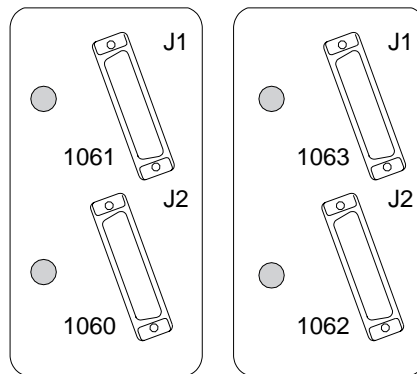

4. Plug in the new Ethernet cable and lock it in place by sliding the latch down and to the right (the closed padlock position).

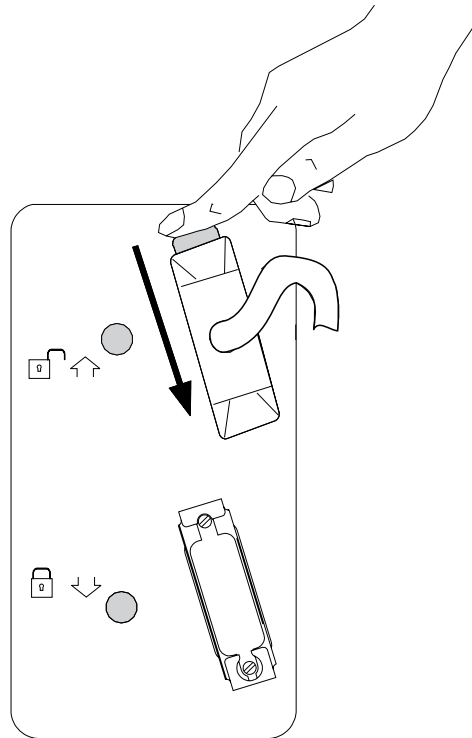

Step 4 Activating the line(s)

Ask the host operator to activate the line(s).

Note: If you have installed a link-attached 3745, make sure that the link IPL port cables are connected before attempting an IPL.

Step 5 You have finished this task

Close and lock the door using the special door key.

Unplugging or Plugging In a Token-Ring Adapter (TRA) Cable

If you have a 3745 Model A without a 3746-900 attached

Do not use this procedure to make changes to the cable that connects the 3745 to the token-ring LAN used by the service processor. These are IBM service representative tasks.

Step 1 Starting

Before beginning you must first do the procedure "Getting Started" on page 2-2.

If you are only plugging in TRA cable(s), go to Step 3 on page 2-8. Otherwise continue with the next step.

Step 2 Unplugging TRA cable(s)

Repeat this step for every TRA cable to be unplugged.

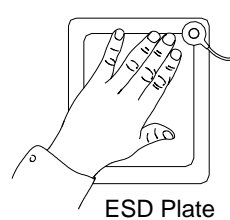

- a. Remove the cable by squeezing the levers and pulling out the plug.

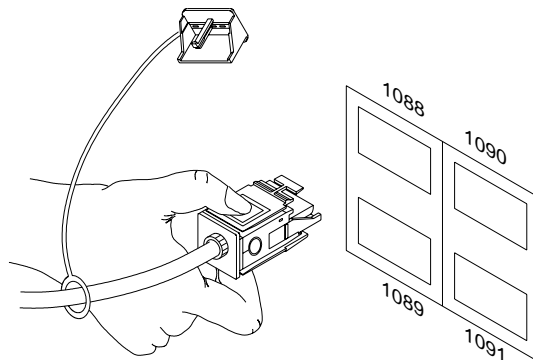

- b. Replace the protective cap on the cable plug.

If you are going to plug in a new cable, continue with the next step.

Otherwise, go to Step 4 on page 2-8.

Step 3 Plugging in TRA cable(s)

Repeat this step for every TRA cable to be plugged in.

Note: Make sure that all the cables are correctly labeled at both ends before doing this step.

- a. Refer to the figures of the Step 2 on page 2-7.
- b. Locate the cable by the port number written on the label.
- c. Touch the electrostatic discharge plate.
- d. Remove the protective cap from the cable plug.
- e. Plug in the new TRA cable by squeezing the levers and pushing the cable into place until it clicks.

Step 4 Upgrade CDF

You must perform the Upgrade procedure in “Upgrading or Updating CDF” on page 5-7. You can either do it now and continue with the next step or later when you have finished all your the connection procedures.

Step 5 Activating lines

Ask the host operator to activate any lines that were plugged in.

Note: The line number is the same as the port number.

Step 6 You have finished this procedure

If you have no other connection procedures to do, close and lock the door using the special door key.

Unplugging or Plugging In a High-Speed Scanner (HSS) Cable

Step 1 Starting

Before beginning you must first do the procedure “Getting Started” on page 2-2.

If you are only plugging in HSS cables, go to Step 3 on page 2-9. Otherwise continue with the next step.

Step 2 Unplugging an HSS cable

Remove the cable by squeezing the levers and pulling out the plug.

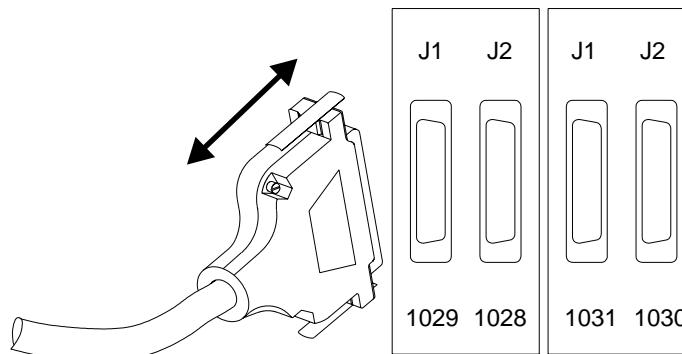

Repeat this step for every HSS cable to be unplugged.

If you are **not plugging in** an HSS cable, go to Step 4 on page 2-9.

Otherwise, continue with the next step.

Step 3 Plugging in an HSS cable

Repeat this step for every HSS cable to be plugged in.

Note:

- Make sure that all the cables are correctly labeled at both ends before doing this step.
 - If you connect the HSS to a DTE equipment (such as IBM 2210 router), for allowing RLSD signal propagation, the DCE side of the cable must be connected to the HSS and the DCE side to the router.
- a. Refer to the figure of the Step 2 on page 2-8.
 - b. Locate the cable by the port number written on the label.
 - c. Plug in the new HSS cable by squeezing the levers and pushing the cable into place until it clicks.

Step 4 Update CDF

You must perform the Update procedure in “Upgrading or Updating CDF” on page 5-7. You can either do it now and continue with the next step or later when you have finished all your connection procedures.

Step 5 Activating the line

Ask the host operator to activate any lines that were plugged in.

Note: If you have installed a link-attached 3745, make sure that the link IPL port cables are connected before attempting an IPL.

Step 6 You have finished this task

Close and lock the door using the special door key.

Unplugging or Plugging In an Operator Console Cable

Attention

This procedure does not apply for Model 17A.

Step 1 Starting

Before beginning you must first do the procedure “Getting Started” on page 2-2.

If you are **only inserting** a console cable, go to Step 3 on page 2-10. Otherwise continue with the next step.

Step 2 Unplugging cable(s)

- a. Ask the operator of the appropriate console to log off.
- b. Touch the electrostatic discharge plate.
- c. Unfasten the cable ground clamp. The cable clamp is fixed at the bottom left of the frame by one of the three wing nuts.



- d. Unplug the cable by squeezing the levers on the top and bottom of the plug and pulling it out.

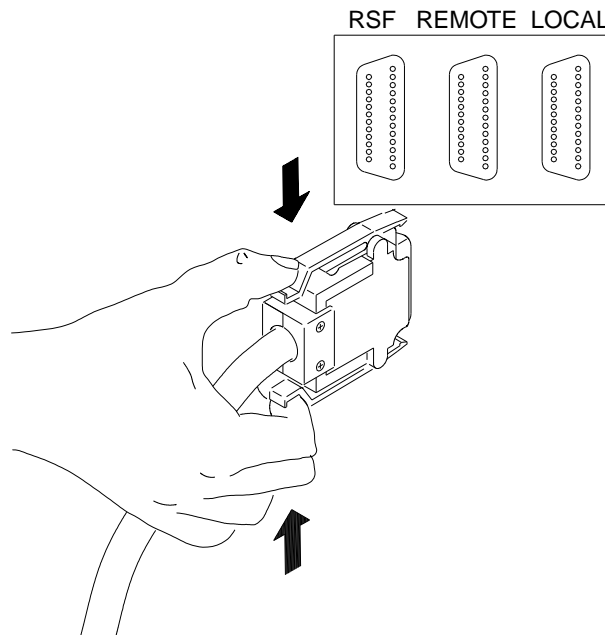

If you are going to plug in a new cable, continue with the next step.
Otherwise, go to Step 4 on page 2-11.

Step 3 Plugging in cable(s)

- a. Refer to the figures of the Step 2.
- b. Locate the cable by the label on the cable.
- c. Touch the electrostatic discharge plate.
- d. Plug in the console cable.
- e. Fasten the cable ground to the frame with the cable clamp. The cable clamp is fixed at the bottom left of the frame by one of the three wing nuts.

Note: The cable clamp serves to reduce the possibility of radio frequency interference that might be caused by the operating machine. Proper installation of the cable clamp is necessary to meet FCC requirements and to conduct electrostatic discharges to ground.

Step 4 You have finished this task

Close and lock the door using the special door key.

Unplugging or Plugging In the Remote Support Facility (RSF) Cable

Attention

This procedure does not apply for Model 17A.

Step 1 Starting

Before beginning you must first do the procedure “Getting Started” on page 2-2.

If you are **only inserting** a console cable, go to Step 3 on page 2-12. Otherwise continue with the next step.

Step 2 Unplugging the DCE cable

- Ask the operator of the appropriate console to log off.
- Touch the electrostatic discharge plate.
- Unfasten the cable ground clamp. The cable clamp is fixed at the bottom left of the frame by one of the three wing nuts.



- Unplug the cable by squeezing the levers on the top and bottom of the plug and pulling it out.

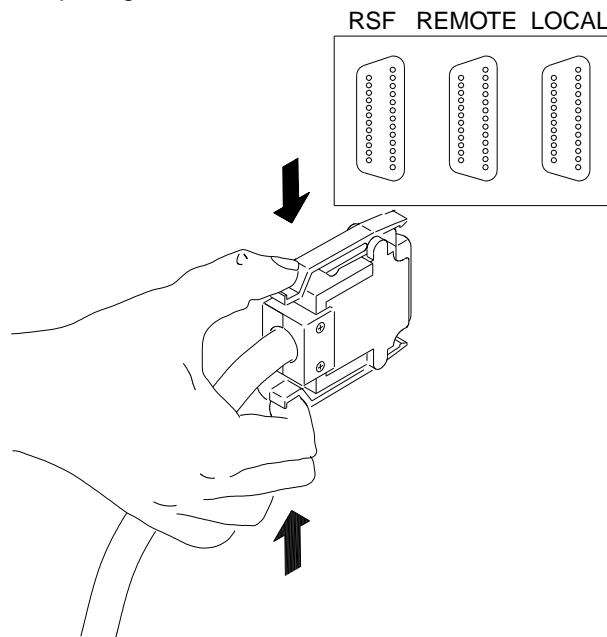

If you are going to plug in a new cable, continue with the next step. Otherwise, go to Step 4 on page 2-12.

Step 3 Plugging in the DCE cable

- a. Refer to the figures of the Step 2 on page 2-11.
- b. Locate the cable by the label on the cable.
- c. Touch the electrostatic discharge plate.
- d. Plug in the RSF cable.
- e. Fasten the cable ground to the frame with the cable clamp. The cable clamp is fixed at the bottom left of the frame by one of the three wing nuts.

Note: The cable clamp serves to reduce the possibility of radio frequency interference that might be caused by the operating machine. Proper installation of the cable clamp is necessary to meet FCC requirements and to conduct electrostatic discharges to ground.

Step 4 You have finished this task

Close and lock the door using the special door key.

Removing or Installing the Customer Power Control (CPC) Cable

Note: The CPC cable and connector are not provided by IBM, and, therefore, are not shown here; neither are the details of securing the CPC cable in place given.

Step 1 Starting

Before beginning, you must first perform the Step 2 on page 2-2 of the procedure "Getting Started" on page 2-2.

If you are **only plugging in** a cable, go to Step 3.

Otherwise, continue with the next step.

Step 2 Unplugging the CPC cable

1. Touch the electrostatic discharge plate.

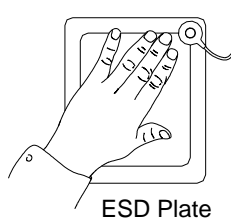

2. Unplug the cable.

If you are going to plug a new cable, continue with the next step.

Otherwise, go to Step 4 on page 2-13.

Step 3 Plugging in the CPC cable

1. Locate the cable by the label on the cable.
2. Touch the electrostatic discharge plate.

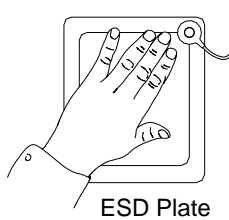

3. Plug in the new cable.

Step 4 You have finished this task

Close and lock the door using the special key.

Removing or Installing a Line Interface Coupler (LIC) or Its Cable

For LIC types 5 and 6, refer to the *LIC5/6 Migration and Integration Guide*, SA33-0416 or earlier version of the *Connection and Integration Guide*, SA33-0129.

LIC Slots: Regardless of the number of ports (lines) that are actually used, four line numbers are allocated for each LIC slot in a LIB 1. These slots hold TSS LIC type 1, 3, and 4.

Line Weights: When reconfiguring LICs, ensure that the total weight of lines connected to a low-speed scanner is within the scanner maximum capacity. To calculate them see Appendix A, “LSS Characteristics and Line Weights.”

Step 1 Starting

Before beginning you must first do the procedure “Getting Started” on page 2-2.

Step 2 Locating the LIB and the LIC slot.

Use the port number(s).

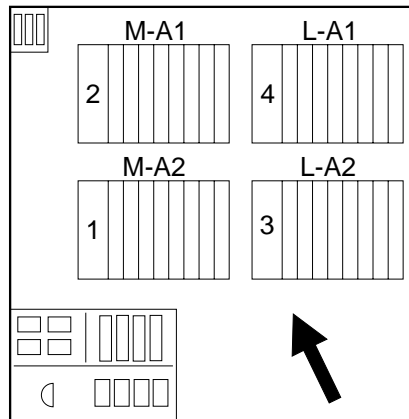

- Boards 1 and 2 are **always** LIB type 1, which can be equipped with LIC type 1, 3, and 4.
- Board 4, when installed, is **always** a LIB type 2, which can be equipped with LIC type 5 and 6 (features no longer available).
- Board 3 may be either a LIB type 1 or a LIB type 2.

For the Model 150 only

LIB position 1 (lower left) is equipped with a LIB type 3 having only four LIC positions. The port numbers are unchanged.

LIB Position 2 (M-A1)

2	032	036	040	044	048	052	056	060
	033	037	041	045	049	053	057	061
	034	038	042	046	050	054	058	062
	035	039	043	047	051	055	059	063

LIB Position 4 (L-A1)

4	080	082	084	086	088	090	092	094
	081	083	085	087	089	091	093	095

LIB Position 1 (M-A2)

1	000	004	008	012	016	020	024	028
	001	005	009	013	017	021	025	029
	002	006	010	014	018	022	026	030
	003	007	011	015	019	023	027	031

LIB Position 3 (L-A2)

3	128	132	136	140	144	148	152	156
	(64)	(66)	(68)	(70)	(72)	(74)	(76)	(78)
	129	133	137	141	145	149	153	157
	130	134	138	142	146	150	154	158
	(65)	(67)	(69)	(71)	(73)	(75)	(77)	(79)
	131	135	139	143	147	151	155	159

Note: For board 3, if a LIB type 1 is installed, use the figures that are not in parentheses for the port numbers; for a LIB type 2 (no longer available from IBM), use the figures in parentheses.

If you are **only installing a LIC**, go to Step 4 on page 2-15.

If you are **only plugging in a LIC cable**, go to Step 8 on page 2-16.

Otherwise, continue with the next step.

Step 3 Deactivating the lines

Ask the host operator to deactivate all the lines connected to the LIC you want to work with.

Attention

Deactivation of all the lines of the LIC is necessary to prevent problems at line adapter restart.

The line number is the same as the LIC port number.

For LIC types 1, 3, and 4:

There are up to four lines per LIC.

For LIC types 5 and 6:

Refer to the *LIC5/6 Migration and Integration Guide*, SA33-0416 or earlier version of the *Connection and Integration Guide*, SA33-0129.

Step 4 Identifying LIC(s)

The LICs are not labeled. To identify a LIC, make a visual inspection.

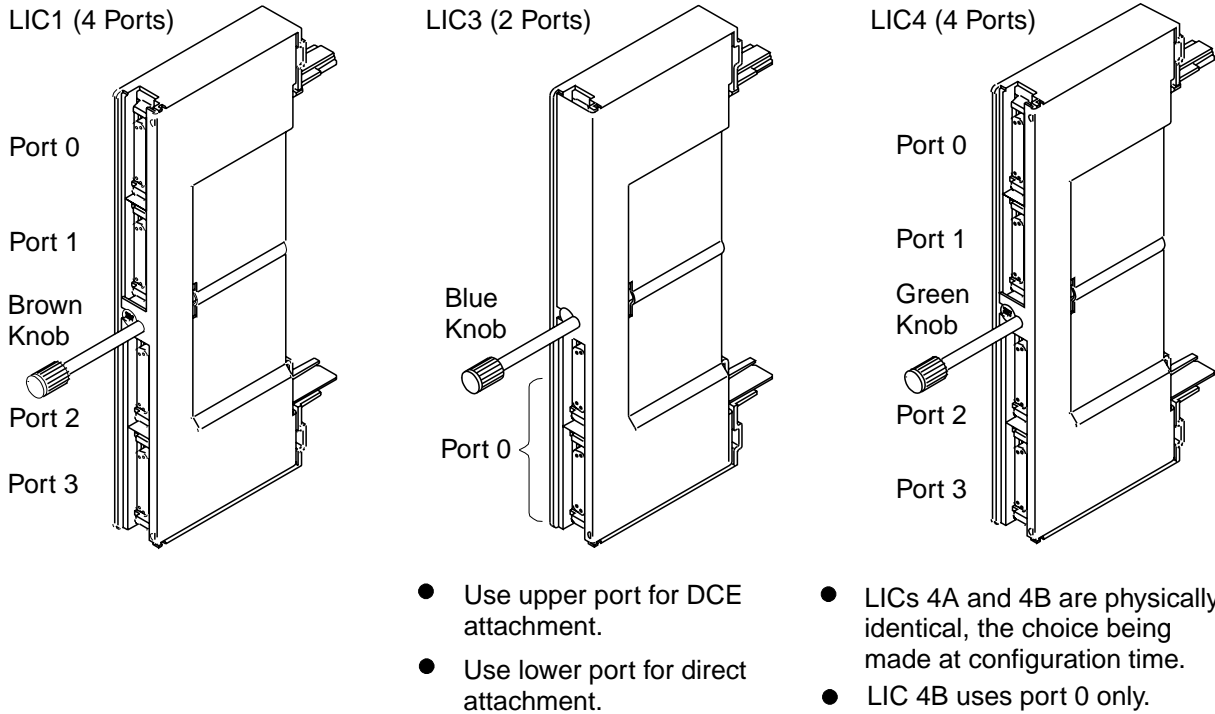
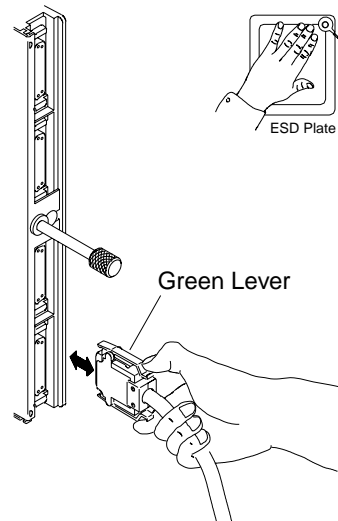

Figure 2-2. LIC Types 1, 3 and 4.

Step 5 Unplugging LIC cable(s)

Repeat this step for every LIC to be removed.

Unplugging LIC types 1, 3, and 4 Cable(s)



Remove the cable by squeezing the side levers and pulling out the plug.

Unplugging LIC types 5 and 6 Cable(s)

Refer to the *LIC5/6 Migration and Integration Guide*, SA33-0416 or earlier version of the *Connection and Integration Guide*, SA33-0129.

If you are **only unplugging** a LIC cable, go to Step 12 on page 2-17

If you **only** want to **plug in** a LIC cable without removing a LIC, go to Step 8.

Otherwise, **to remove LIC(s)**, continue with the next step.

Step 6 Removing LIC(s)

1. Turn the knob counterclockwise to unlock the LIC.
2. Remove the LIC by delicately pulling it out.

Repeat this step for every LIC to be removed.

If you have **no LICs to install**, go to Step 9 on page 2-17

Otherwise, continue with the next step.

Step 7 Inserting LIC(s)

Repeat this step for every LIC to be inserted.

- a. Touch the electrostatic discharge plate.

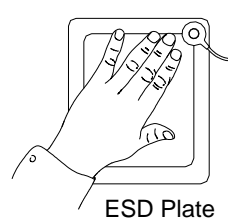

- b. Ensure that the slot is clear. If necessary, carefully remove the bundle of cables for this LIC row from behind the cable retaining bracket.

Note: Do not forget to replace the cables behind the retaining bracket when finished.

- c. Hold the LIC so that the black plastic side is on the left and the knob is pointing toward you.
- d. Push the LIC into the slot until it clicks.
- e. Turn the knob clockwise to lock the LIC in place.

Step 8 Plugging in LIC cable(s)

Note: The cable-retaining bar and ground plate assembly at the base of the machine may be removed to allow easier access to the cables. Remove the two wing screws and lift it out:

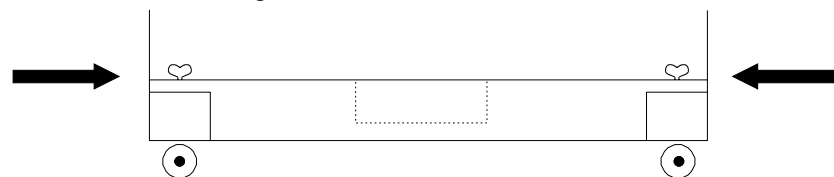

If there is no raised floor, remove the retaining bar only.

Note: For your convenience, plug the lower cables first.

1. Locate the cable using the port number written on the label.
2. Orient the plug and push it strongly into the corresponding port in the LIC, until it clicks.

If necessary, examine the port and the socket to orient the plug correctly before insertion.

If the LIC is a type 3, check the plugging diagram to determine which of the two sockets should be used.

Repeat this step for every LIC or LIC cable to be installed.

Step 9 Updating the CDF

Go to “Upgrading or Updating CDF” on page 5-7 and perform the steps as instructed, then continue with the next step.

Step 10 Testing the LIC 1, 3, or 4

If you only removed LIC or LIC cables, go to Step 12.

For new LIC or LIC cables installed, refer to the wrap test (WTT) function in the *Advanced Operations Guide*, SA33-0097 and perform the automatic wrap test at the LIC level. NCP must be loaded to run WTT.

Step 11 Activating lines

Ask the host operator to activate the line(s) of all newly installed LIC(s) or LIC cable(s).

Attention

If one of the affected lines was not deactivated at Step 3 on page 2-14, you may be forced to re-load the NCP.

Step 12 You have finished this procedure

If you have no other connection tasks to do, replace the cable-retaining bar and ground plate assembly (if you removed it at Step 8 on page 2-16), close, and lock the door using the special key.

Note: The ground plate serves to reduce the possibility of radio frequency interference that might be caused by the operating machine. A proper installation of the ground plate is necessary to meet FCC requirements, and to conduct electrostatic discharges to ground.

Chapter 3. 3746-900: Installing LCBs and ARCs, Connecting Cables

The 3746-900 can be powered ON while doing these procedures.

Attention

By touching inside the machine you can cause electrostatic discharges (ESD) that may result in errors in the system operation, or damage to the equipment.

Therefore, it is very important that you touch this ESD plate before you touch any element inside a unit or before you plug in a cable.

The (ESD) plate is located on the inside face of the frame door.

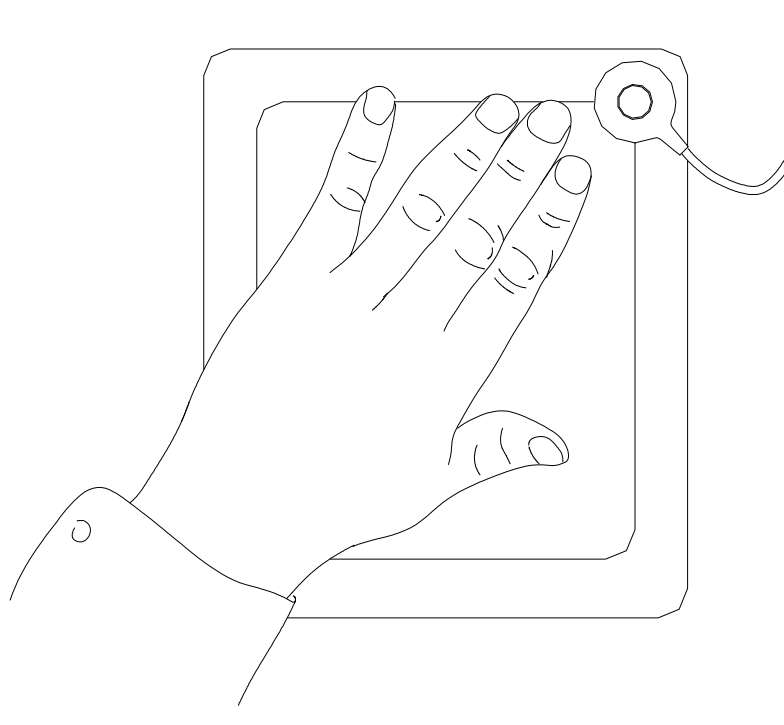

Connection Tasks

The connection tasks in this chapter are for:

- Ethernet Bridge
- Multiaccess Enclosure
- Token-ring Interface Couplers (TIC3s)
- Line Interface Couplers (LIC 11s and LIC 12s)
- Line Connection Boxes (LCBBs and LCBEs)
- Active Remote Connectors (ARCs)
 - ARC assembly A : the cable is permanently attached to the ARC
 - ARC assembly B : the cable is separate from the ARC.

Note: The ARC color is **light grey**.

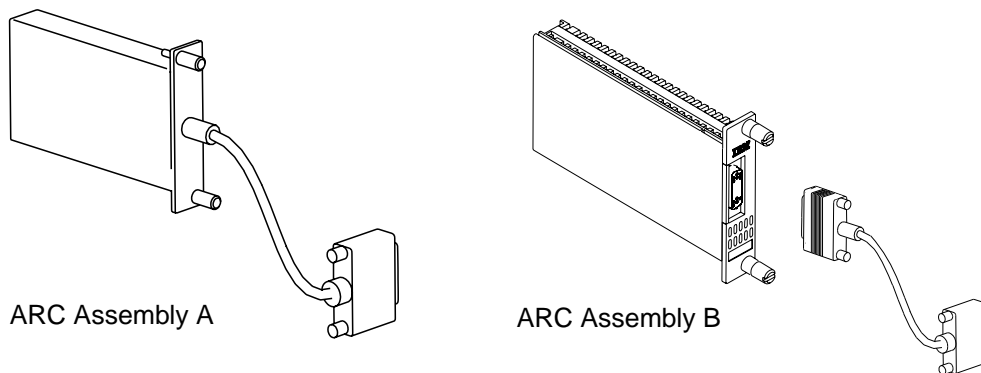

Figure 3-1. ARC Assembly A and B

The LCBs and ARCs can be located either in the 3746-900 base-frame, in the controller expansion, or in a stand-alone 19 inch rack. The Ethernet Bridge and the Multiaccess Enclosure are located either in the controller expansion or a stand-alone 19 inch rack. Refer to Figure 3-2 on page 3-3 and Figure 3-4 on page 3-4 for base-frame and controller expansion mounted elements.

Starting Connection Tasks

Labels

Before the initial installation, all external cables from DTEs/DCEs to the 3746-900 must be labeled. Do not forget to add or change the cable labels when you make later modifications.

Step 1 Obtain the necessary line plugging sheets from the *Migration and Planning Guide*, GA33-0183.

If you are not working with 3746-900 base frame-mounted elements, go to the following sections as needed:

- “Unplugging or Plugging In an Ethernet LAN Cable” on page 3-9
- “Unplugging or Plugging in a Multiaccess Enclosure Adapter Cable” on page 3-12
- “Installing an LCB” on page 3-13
- “Removing or Installing ARC Assembly A” on page 3-18
- “Removing or Installing ARC Assembly B” on page 3-24

Otherwise, continue with the next step.

Step 2 Open the rear door of the 3746-900 by pushing in and turning the screws (located in upper and lower corner of the door), using the controller door key.

Step 3 Locate a coupler slot

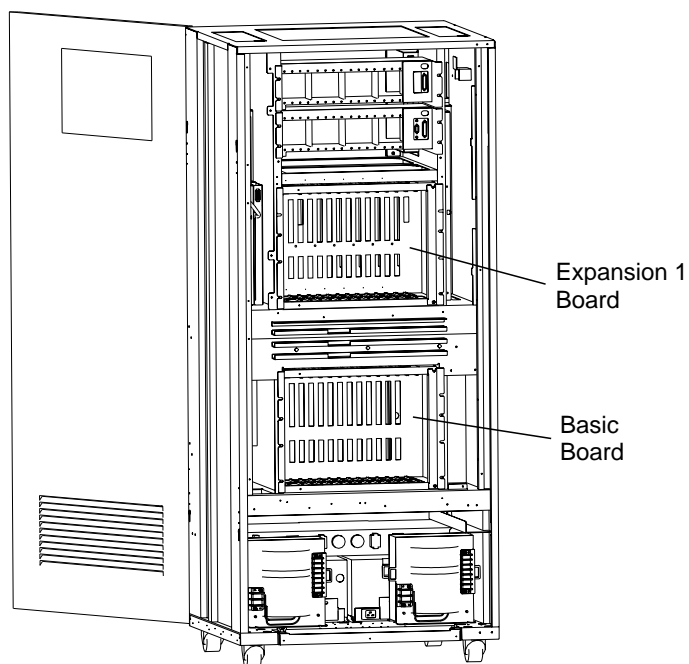

Figure 3-2. 3746-900 Rear View (the Coupler Side)

The slot addresses are above the enclosure slots. The coupler slots are labeled according to their address range:

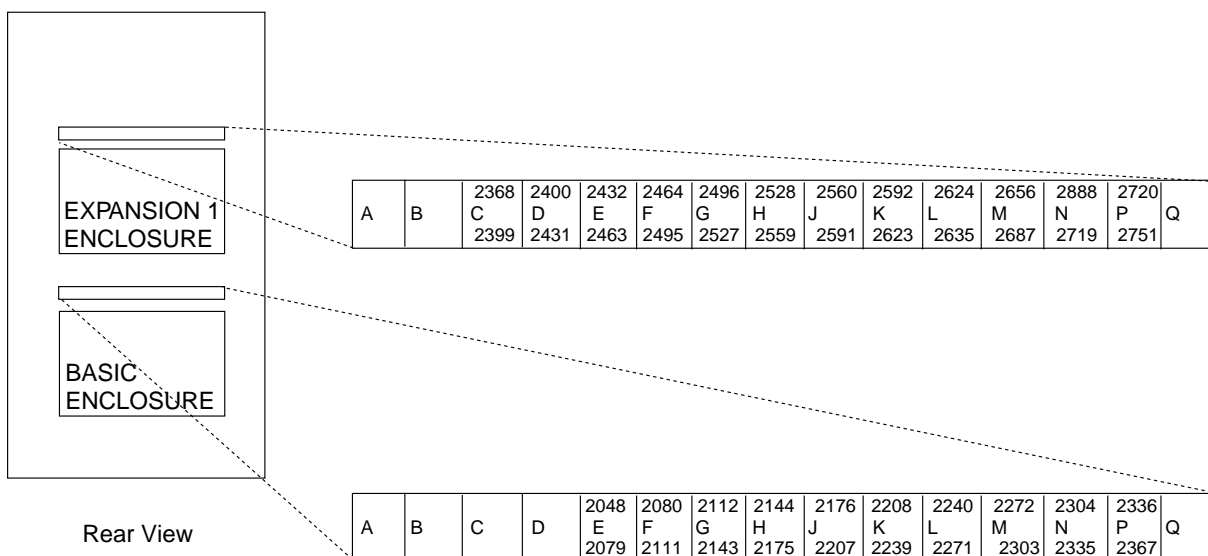

Figure 3-3. Addresses for the Enclosures

When you have finished locating all the coupler slots needed, go to the following as necessary:

- “Unplugging or Plugging in a TIC3 Cable” on page 3-5
- “Unplugging or Plugging in LIC Cables” on page 3-7
- The next step to locate an LCB.

Step 4 Locate the line connector boxes (LCBs)

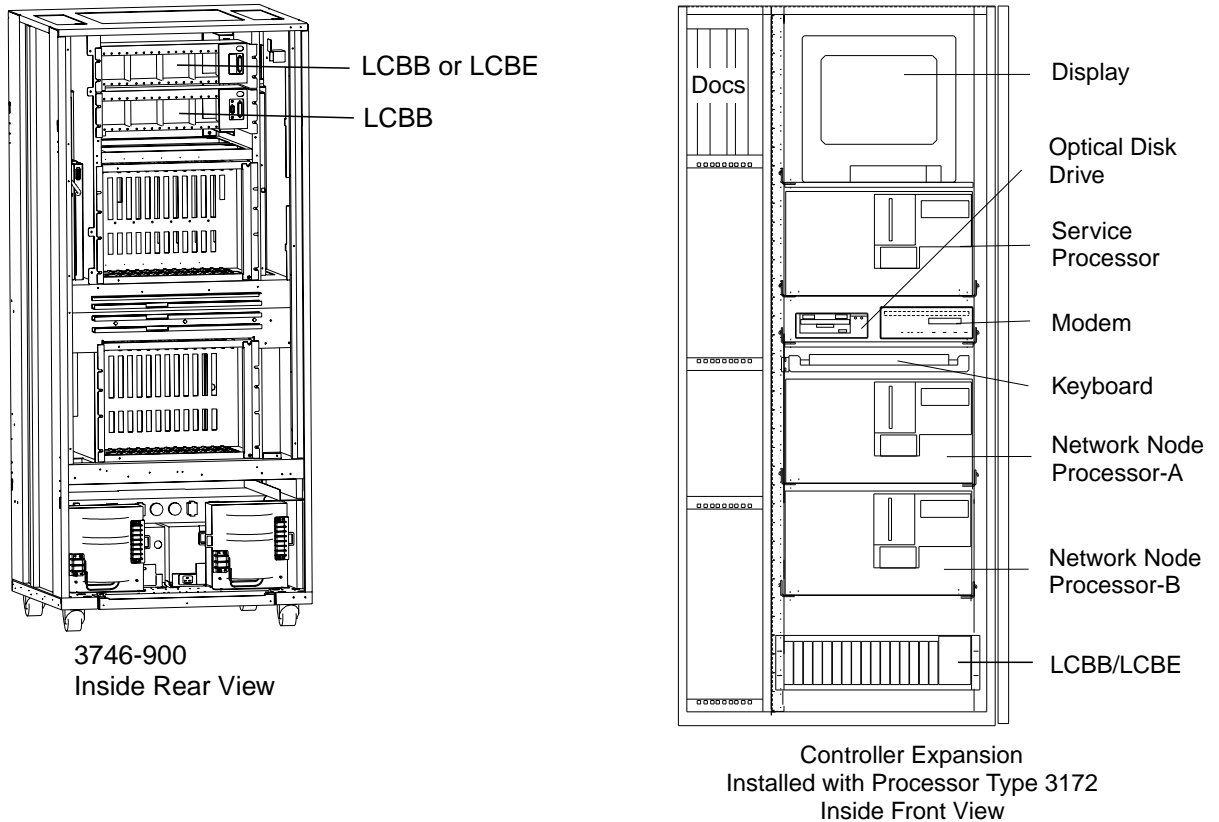

Figure 3-4. 3746-900 LCBs Locations Example in the Base Frame and the Controller Expansion.

When you have located the LCBs, go to the following sections as needed:

- “Removing or Installing ARC Assembly A” on page 3-18
- “Removing or Installing ARC Assembly B” on page 3-24

Unplugging or Plugging in a TIC3 Cable

BEFORE BEGINNING

Do the "Starting Connection Tasks" on page 3-2 before beginning this task.

Two types of cable can be attached to the TIC3:

- Token-ring attachment cable.
This shielded twisted pair (STP) cable is only available from IBM.
- Untwisted pair (UTP) cable.
This type of cable connects to the TIC3 using the IBM Token-Ring MAU Media Filter. It is not available from IBM.

Attention

This section does not apply for TIC3 cables:

- used for the Service Processor Access Unit
- connected to an Ethernet Bridge (refer to "Unplugging or Plugging In an Ethernet LAN Cable" on page 3-9).

If you are:

- Unplugging an attachment cable, start at Step 1
- Plugging in an attachment cable, start at Step 2 on page 3-6
- Unplugging a UTP cable, start at Step 3 on page 3-6
- Plugging in a UTP cable, start at Step 5 on page 3-7.

Step 1 Unplugging an attachment cable

Ask the network operator to deactivate the line to be disconnected.

Loosen the retaining screws and pull out the connector.

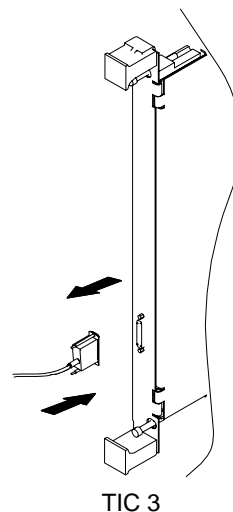

Figure 3-5. Installing or Removing a Token-Ring Attachment Cable

Repeat this step for every attachment cable to be unplugged.

If you are only **unplugging** an attachment **cable**, go to Step 8 on page 3-7. Otherwise, continue with the next step.

Step 2 Plugging in an attachment cable

For this step, see Figure 3-5 on page 3-5.

Check that the cable is correctly labeled at both ends.

Push in the connector and tighten retaining screws.

Repeat this step for every cable to be plugged in.

When all token-ring attachment cables have been inserted, go to Step 7 on page 3-7.

Step 3 Unplugging a UTP cable

Ask the network operator to deactivate the UTP-connected line to be removed.

Pinch the UTP cable connector and pull it out. See 'A' in Figure 3-6.

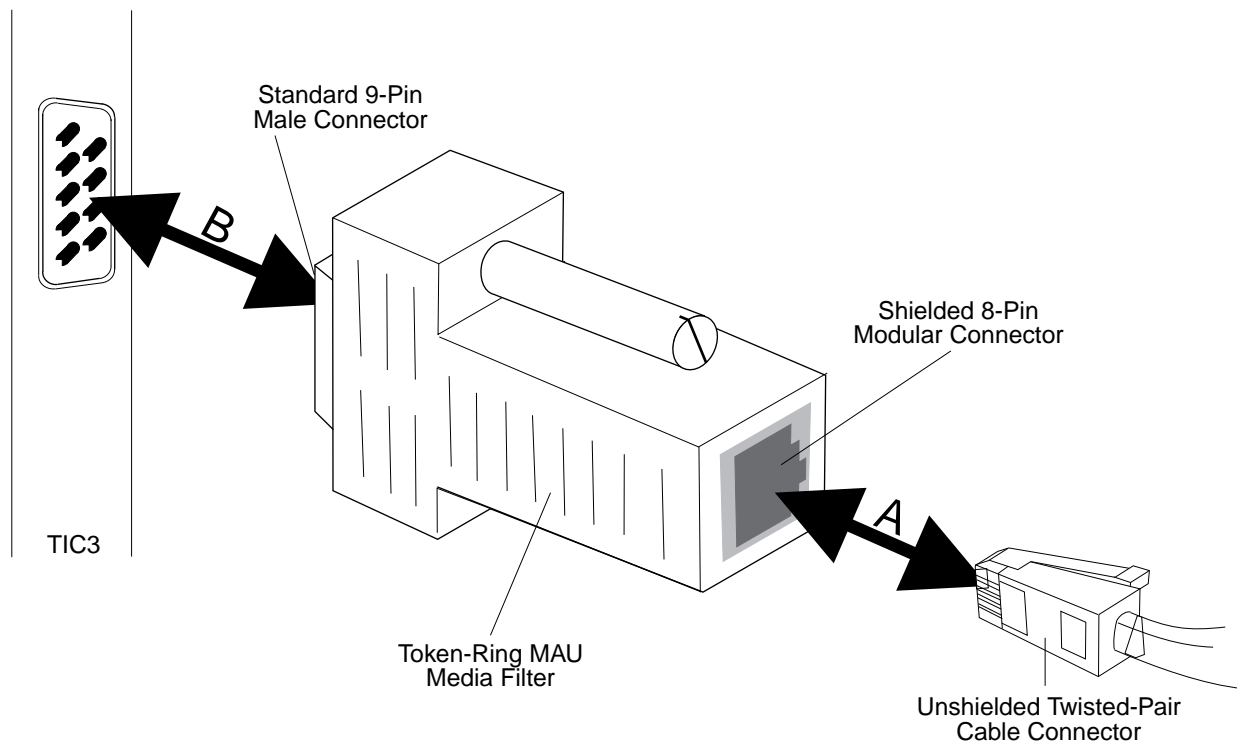

Figure 3-6. Installing or Removing a Token-Ring UTP Cable and Media Filter

Step 4 Unplugging a Token-Ring UTP Media Filter

Ask the network operator to deactivate the UTP-connected line to be removed.

Loosen the retaining screws and pull out the media filter. See 'B' in Figure 3-6.

If you are only **unplugging** a UTP **cable**, go to Step 8 on page 3-7. Otherwise, continue with the next step.

Step 5 Plugging in a Token-Ring UTP Media Filter

Check that the cable is correctly labeled at both ends.

Insert the media filter into the TIC3 connector and tighten the retaining screws. See 'B' in Figure 3-6 on page 3-6.

Step 6 Plugging in a UTP cable

Push the connector into the media filter socket until it clicks into place. See 'A' in Figure 3-6 on page 3-6.

When all the UTP cables have been connected, continue with the next step.

Step 7 Activating the line

Ask the network operator to activate the lines of any newly installed or replaced cables. If the activation is not possible, inform the IBM representative.

Step 8 Update the plugging sheets

You have finished this procedure. To integrate the changes that you have made, go to "Updating the Active CDF-E (3746-900 Only)" on page 5-1.

Unplugging or Plugging in LIC Cables

BEFORE BEGINNING

Do the "Starting Connection Tasks" on page 3-2 before beginning this task.

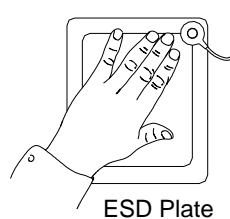

Step 1 If you are only plugging in a coupler cable, go to Step 3 on page 3-8.

Otherwise, continue with the next step.

Step 2 Unplugging a coupler cable

Ask the network operator to deactivate the affected lines.

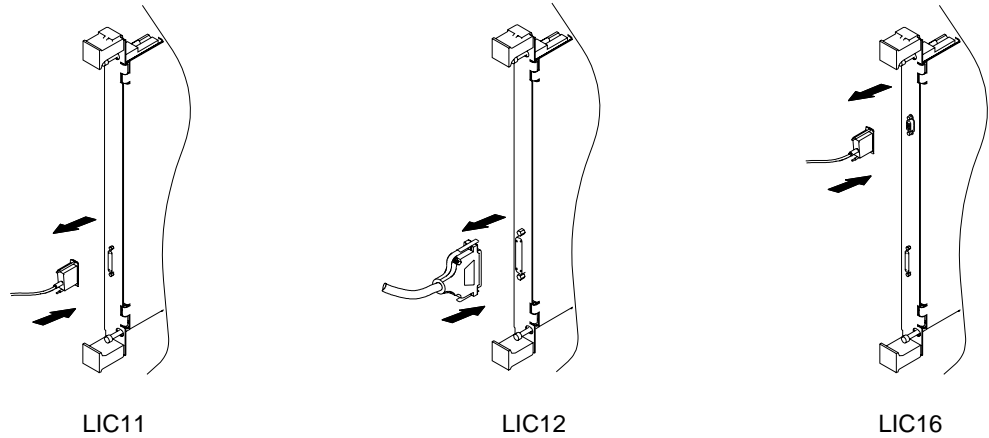

Figure 3-7. The LIC 11, LIC 12, LIC 16, and Their Cables

Loosen the retaining screws and pull out the connector.

If you are not plugging in a coupler cable, go to Step 4.

Otherwise, continue with the next step to plug in a coupler cable.

Step 3 Plugging in a coupler cable

For this step, see figure 3-7.

Note:

- Make sure that all the cables are correctly labeled at both ends before doing this step.
- If you connect a LIC 12 to a DTE equipment (such as IBM 2210 router), for allowing RLSD signal propagation, the DCE side of the cable must be connected to the HSS and the DCE side to the router.

Push in the connector and tighten the retaining screws.

Step 4 Update the plugging sheets

You have finished this procedure. To integrate the changes that you have made, go to “Updating the Active CDF-E (3746-900 Only)” on page 5-1.

Unplugging or Plugging In an Ethernet LAN Cable

Important to know before starting this procedure

- Install only AUI cables that conform to ISO 8802-3.

The ISO 8802-3 says:

"The connector is not specified to prevent operator contact with the shield, precautions shall be taken at installation time to ensure that the installer is warned that the shield is not brought into contact with any hazardous voltage while being handled by operating personnel."

- To attach your communication controller to the Ethernet LAN the SQE TEST switch on the Access Unit must be set to ENABLE. If this is not done, when you connect the cable to the 3746-900, operation of the Ethernet LAN may be interrupted.
- Replacing an AUI cable by a 10BASE-T cable is not a customer's task. Ask the IBM representative.

Unplugging or Plugging In an AUI Cable

Step 1 Starting

Before beginning, you must first do the procedure "Starting Connection Tasks" on page 3-2

Note: There is a locking latch attached to the AUI connector. It is sometimes difficult to move.

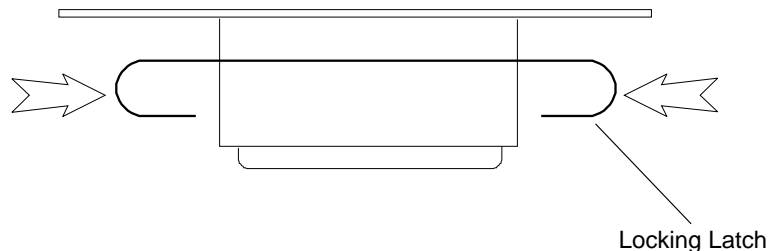

If you are **only plugging in** an AUI cable, go to Step 3 on page 1-9

Otherwise, continue with the next step.

Step 2 Unplugging an AUI cable cable.

Ask the network operator to deactivate the affected lines.

Unlock the latch by pushing it to the left. It may require a lot of force to move it.

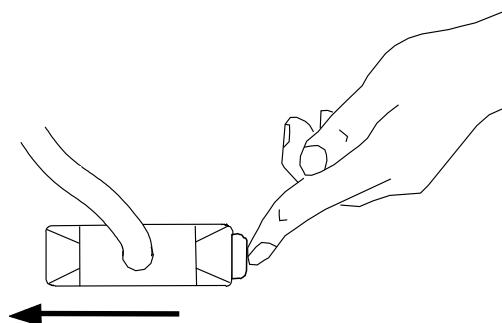

Step 3 Pull out the plug.

If you are **not plugging in** an AUI, go to Step 6 on page 3-11.

Otherwise, continue with the next step.

Step 4 Plugging in an AUI cable

Repeat this step for every AUI to be plugged in.

Note: Make sure that all the cables are correctly labeled at both ends before doing this step.

1. Locate a cable with a label. Find the port that matches the cable.
2. Slide the latch to the left.

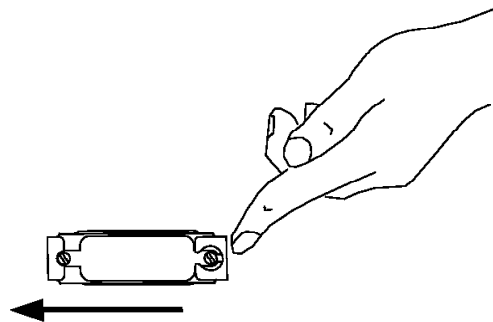

3. Hold the cable connector so that its longest side is upward.

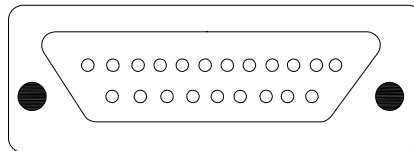

4. Push the plug strongly into the port connector.

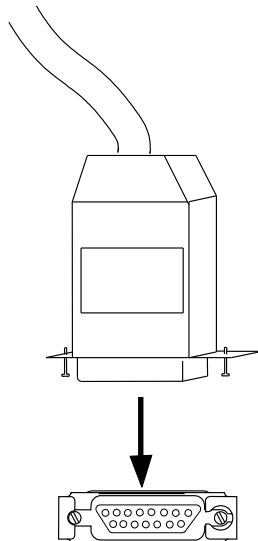

5. Push the locking latch to the right to lock it. It may require a lot of force to move it.

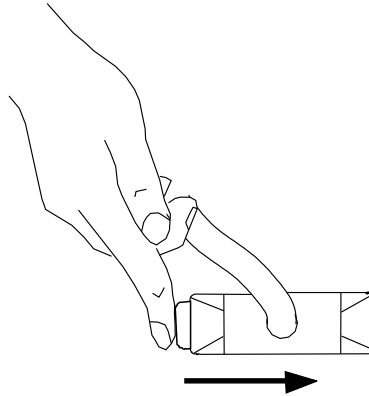

6. To check that the cable is locked in place, move the cable connector from side-to-side while trying to pull it out of the 3746-900 AUI connector. **Do not jerk** on the cable.

Step 5 Activating the lines

Ask the network operator to activate any lines plugged in.

Note: The line number is the address of the TIC3 that connects the Ethernet attachment feature.

Step 6 You have finished this procedure

Close and lock the door using the special door key.

Unplugging or Plugging In a 10BASE-T Cable

Step 1 Starting

Before beginning, you must first do the procedure “Starting Connection Tasks” on page 3-2

The 10BASE-T connector is next to the AUI connector on the Ethernet Bridge.

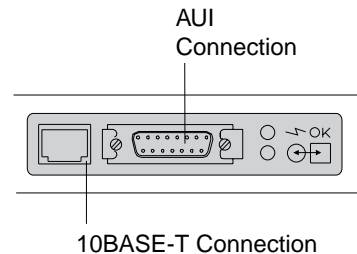

If you are **only plugging in** a 10BASE-T cable, go to Step 3 on page 3-12.

Otherwise, continue with the next step.

Step 2 Unplugging a 10BASE-T cable.

Ask the network operator to deactivate the affected line.

1. Unlock the latch by pressing it.
2. Pull out the plug.

If you are **not plugging in** a 10BASE-T cable, go to Step 5 on page 3-12.

Otherwise, continue with the next step.

Step 3 Plugging in a 10BASE-T cable

Repeat this step for every AUI to be plugged in.

Note: Make sure that all the cables are correctly labeled at both ends before doing this step.

1. Locate a cable with a label. Find the port that matches the cable.
2. Press the latch.
3. Push the plug into the port connector until it clicks onto place.

Step 4 Activating the lines

Ask the network operator to activate any lines plugged in.

Step 5 You have finished this procedure

Close and lock the door using the special door key.

Unplugging or Plugging in a Multiaccess Enclosure Adapter Cable

BEFORE BEGINNING

Do the "Starting Connection Tasks" on page 3-2 before beginning this task.

Step 1 Starting

Before beginning, you must first do the procedure "Starting Connection Tasks" on page 3-2

Step 2 Locating the cable

They are connected to the Multiaccess Enclosure installed in a Controller Expansion

Step 3 Unplugging a cable

Disable the interface as follows:

- a. In the 3746-9x0 Menu, double-click on **Multiaccess Enclosure (MAE) Management**
- b. Double-click on **Manage Multiaccess Enclosure**
- c. Double-click on **MOS** push-button
- d. Type **T 6** then press **Enter** twice to reach the **Config>** prompt
- e. Type **list device** for displaying the interface number of the cable you want to unplug (shown as ifc x)
- f. Type **disable interface ifc x**
- g. (Optionnal) Type **write** for saving your changes
- h. Unplug the cable

Step 4 If you are not plugging in an MAE cable, the procedure is finished.

Otherwise continue with the next step.

Step 5 Plugging in an MAE cable

Note: Make sure that all cables are correctly labeled at both ends before doing this step.

- a. Plug-in the cable into the appropriate connector
- b. If not already done at Step 3 on page 3-12, access the command line interface as follows. Otherwise continue with the Step 5c.
 - 1) In the 3746-9x0 Menu, double-click on **Multiaccess Enclosure (MAE) Management**
 - 2) Double-click on **Manage Multiaccess Enclosure**
 - 3) Double-click on **MOS** pushbutton
- c. Type **T 6** then press **Enter** twice to reach the **Config>** prompt
- d. Type **enable interface ifc x** according to the cable you installed.
- e. Type **write** for saving your changes
- f. Press **Ctrl** and **P** keys
- g. Type **reload**

Note: All MAE traffic will be interrupted while reloading.
- h. Type **yes** or wait for a maintenance time.

Installing an LCB

BEFORE BEGINNING

Do the "Starting Connection Tasks" on page 3-2 before beginning this task.

Line connection boxes (LCBs) house up to 15 active remote connectors (ARCs), thus allowing 15 communication lines to be multiplexed into the same LIC 11. Two LCBs can be used with the same LIC 11 for a total of 30 lines.

There are two types of line connection boxes (LCBs):

Line Connection Box Base (LCB base or LCBB)

The LCB base connects to the LIC 11 and contains slots for 15 lines labelled 0 through 14.

Line Connection Box Expansion (LCB expansion or LCBE)

The LCB expansion connects to the LCB base and contains slots for 15 lines labelled 16 through 30.

Location of LCB Installation

- **LCBs must not be used if not fastened to a table or the floor or not connected to ground.**
- IBM recommends LCBs installation in either the 3746-900 base frame, a 19 inch rack, or in a controller expansion (refer to Figure 3-2 on page 3-3 and Figure 3-4 on page 3-4).
 - Only IBM representatives can install LCBs in the 3746-900 base frame.
 - You can only install LCBs in the 19 inch racks and controller expansion.

Use the following procedure to install LCBs in a rack:

Step 1 Identify the LCB Types

You can identify the two types of LCBs (*bases* and *expansions*) by the different numbering of the ARC slots, and by the connectors on the right side of the front of the chassis.

The LCB **base** (LCBB) has:

- ARC slots labeled +0 through + 14
- Two connectors for the cables to the:
 - LIC 11
 - LCB expansion.

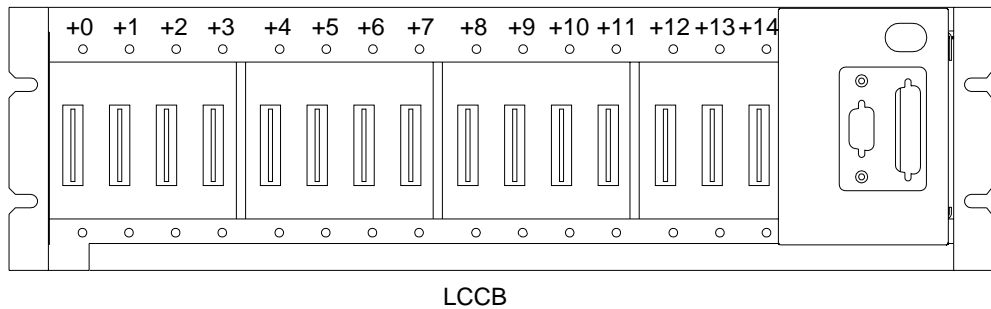

Figure 3-8. LCB Base

The LCB **expansion** (LCBE) has:

- ARC slots labeled +16 through + 30
- One connector for the cable going to the LCB base.

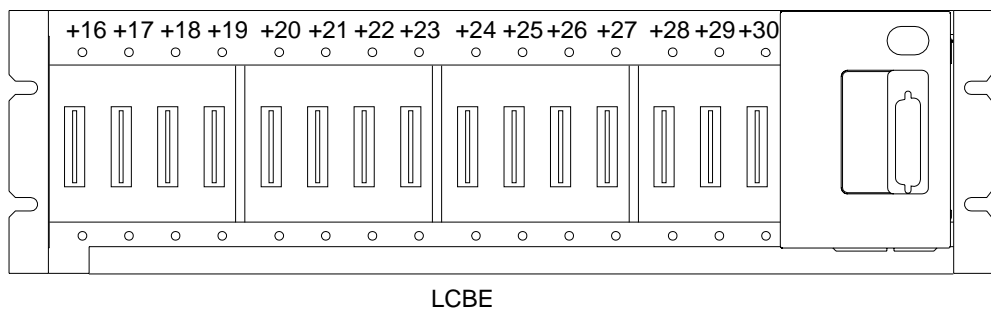

Figure 3-9. LCB Expansion

Step 2 Label the LCBs

a. Verify that the following information about this LCB from the plugging sheet is on the LCB label (part number 63F2503):

- IBM 3746-900 name
- LCB:
 - Number
 - Location
- Range of the LIC 11 addresses.

b. Stick the LCB label on the inner left side of the LCB (see **3** in Detail A of Figure 3-10).

If a label already exists, then stick the new one on top of the old label.

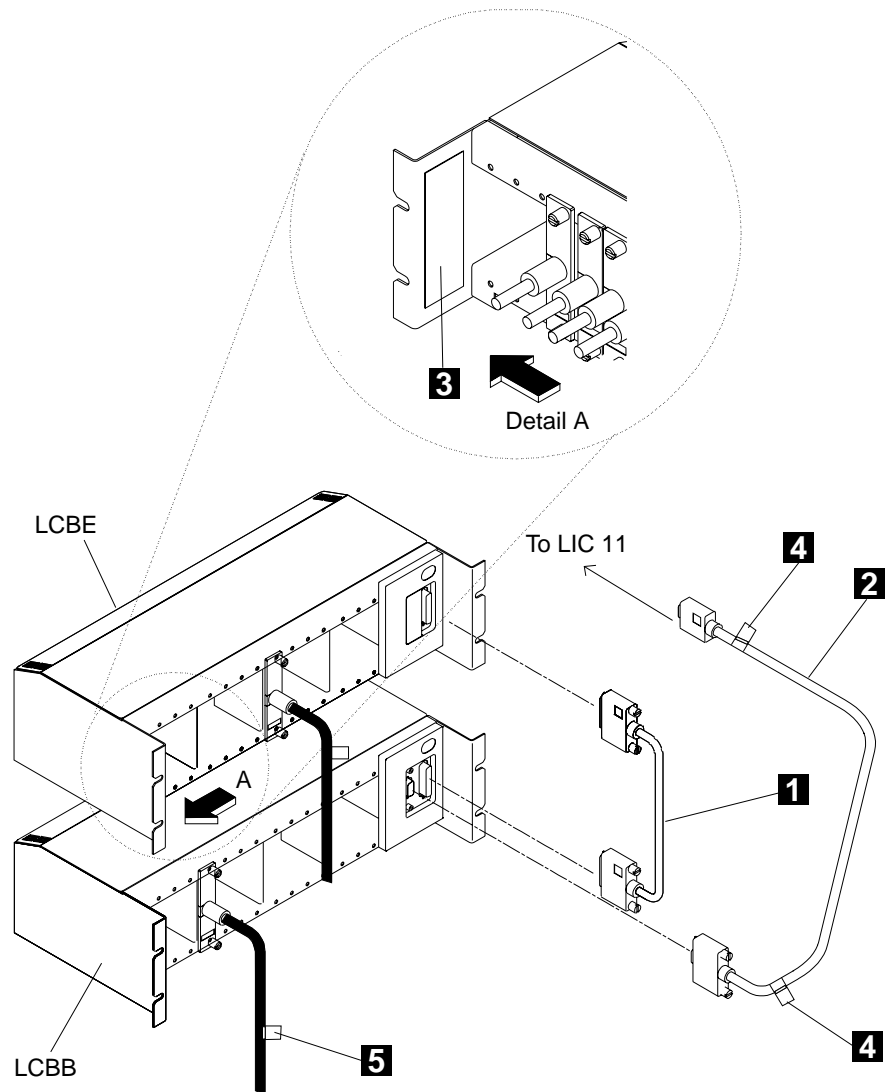

Figure 3-10. LCB Base and LCB Expansion Connections Installed with ARC Assembly A.

Step 3 Install the LCB

- On a table or the floor, continue with the next step.
- In a controller expansion or a 19 inch rack proceed as follows:

Future expansion?

Consider leaving a space above any LCB base that does not yet have an LCB expansion. This makes any future installation of an LCB expansion easier. To do this, leave a 4U space¹ above each LCB base.

- a. Install each LCB expansion directly above the LCB base to which it attaches.
- b. Insert each LCB strongly in the rack.
- c. Secure the LCB using the four screw sets supplied with the LCB.
- d. If you are installing an LCBE, go to Step 5 on page 3-17, otherwise go to Step 6 on page 3-17.

Step 4 Grounding the LCB

When the LCB is **not** installed in a 3746-900, a controller expansion or a 19 inch rack with connection to the premises grounding system, a ground wire must be installed to ensure this connection. Refer to Figure 3-11.

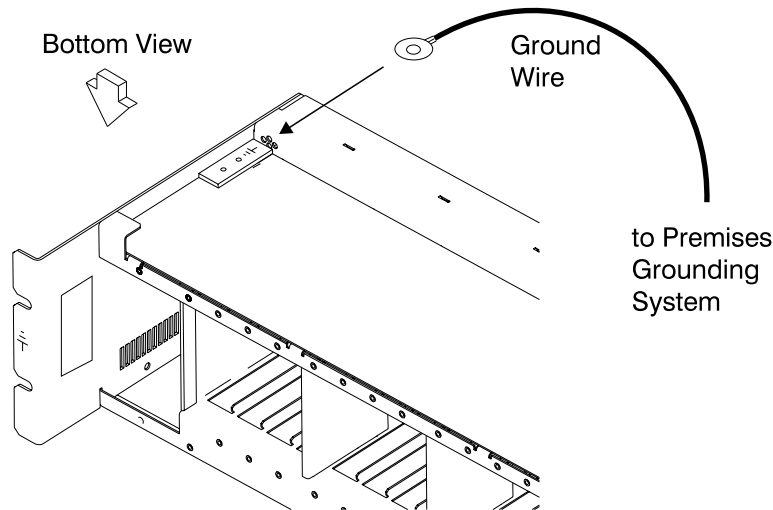

Figure 3-11. LCB Grounding

IBM does not provide this wire. In order to insure a good grounding, it is recommended to use AWG 12 wire (minimum 2.5 square millimeter).

Screw: 5 mm of diameter, length from 6 mm to 10 mm (refer to Figure 3-12 on page 3-17).

¹ One international unit for height (1U) equals 44.45 mm or 1.75 inches.

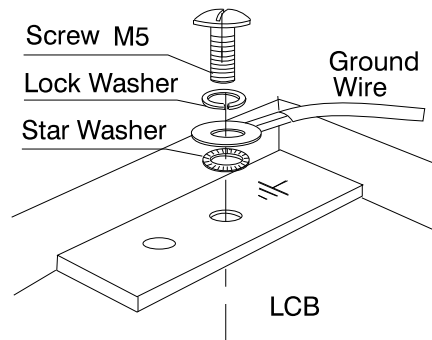

Figure 3-12. Standard Grounding Connection

Step 5 If you are installing an LCB expansion then:

- a. Connect the cable supplied with the LCB expansion between the LCB expansion and its LCB base.

It does not matter which end of the cable is attached to the LCB base.

There is no label for this cable.

- b. Tighten the retaining screws on the cable connectors.

Step 6 Label the LIC 11 cables using two LIC 11 labels (part number 63F2504).

- a. Record the following information from the plugging sheets onto the labels:

- IBM 3746-900 name
- LCB:
 - Number
 - Location
- Range of the LIC 11 addresses.

- b. Stick two identical labels at both ends of the cable (see the two **4**s in Figure 3-10 on page 3-15).

Step 7 Connect the LIC 11 cable to the LCB base and tighten the cable plug retaining screws. Refer to “Unplugging or Plugging in LIC Cables” on page 3-7 for details, and also **2** in Figure 3-10 on page 3-15.

Go to the following sections as needed:

- “Removing or Installing ARC Assembly A” on page 3-18
- “Removing or Installing ARC Assembly B” on page 3-24.

Removing or Installing ARC Assembly A

BEFORE BEGINNING

Do the “Starting Connection Tasks” on page 3-2 before beginning this task.

Use the following procedure to install or remove the active remote connector (ARC) assembly A:

Step 1 Identify the ARC assembly A

The ARC assembly A has a permanently attached cable which has a connector that corresponds to the physical interface of the ARC:

Note: The ARC color is **light grey**.

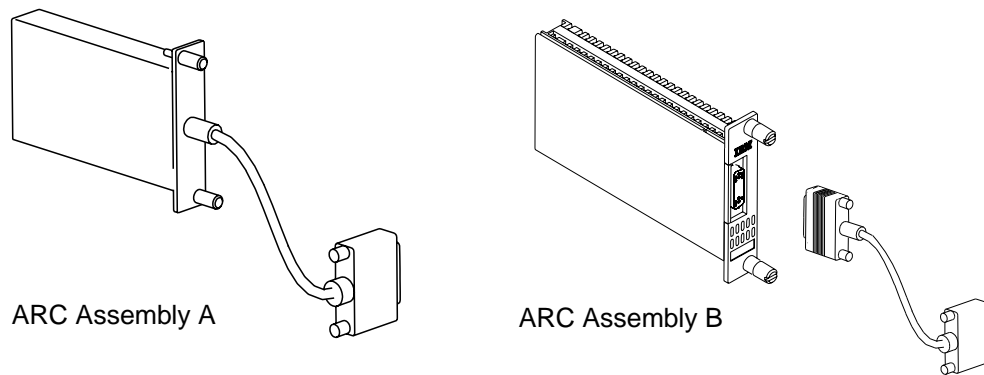
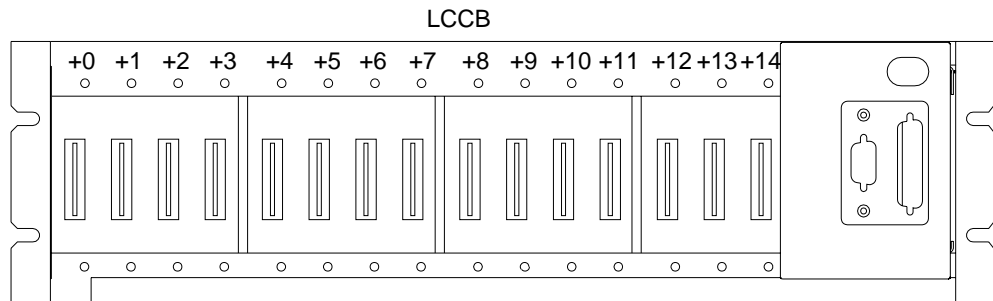
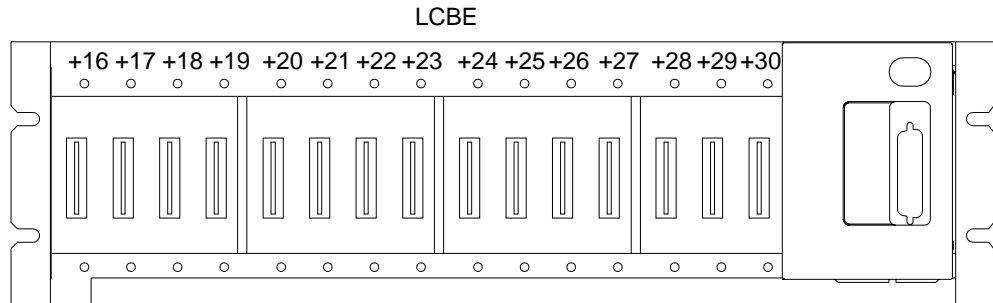

Figure 3-13. ARC Assembly A and B

The cables are available in a range of cable lengths (for more details of available cable lengths, refer to the *Migration and Planning Guide*, GA33-0183).

Step 2 Locate the ARC slot in the line connection box (LCB). An LCB pair, the base (LCBB) and expansion (LCBE), contains a total of 30 slots:



Step 3 If you are only installing an ARC , then go to Step 7 on page 3-21.

Otherwise, ask the network operator to deactivate the ARC communication lines that you wish to unplug.

Step 4 Unplug the ARC cable from the DTE/DCE or the 3745-type connector.

When disconnecting a 3745-type connector:

- a. Hold the connectors with both hands.
- b. With one hand squeeze the side levers and at the same time use both hands to pull the two connectors apart with side-to-side rocking motion.
- c. Store the connecting seal with the ARC for future use.

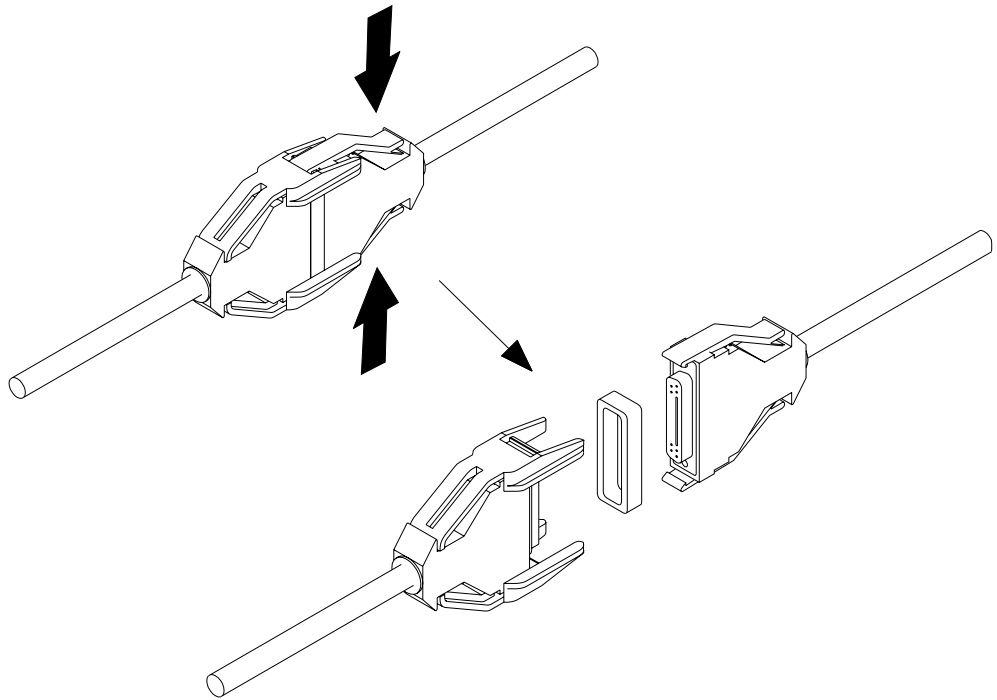

Repeat this step for every ARC cable to be removed.

Step 5 Remove an ARC from the LCB

Loosen the retaining screws and pull out the ARC.

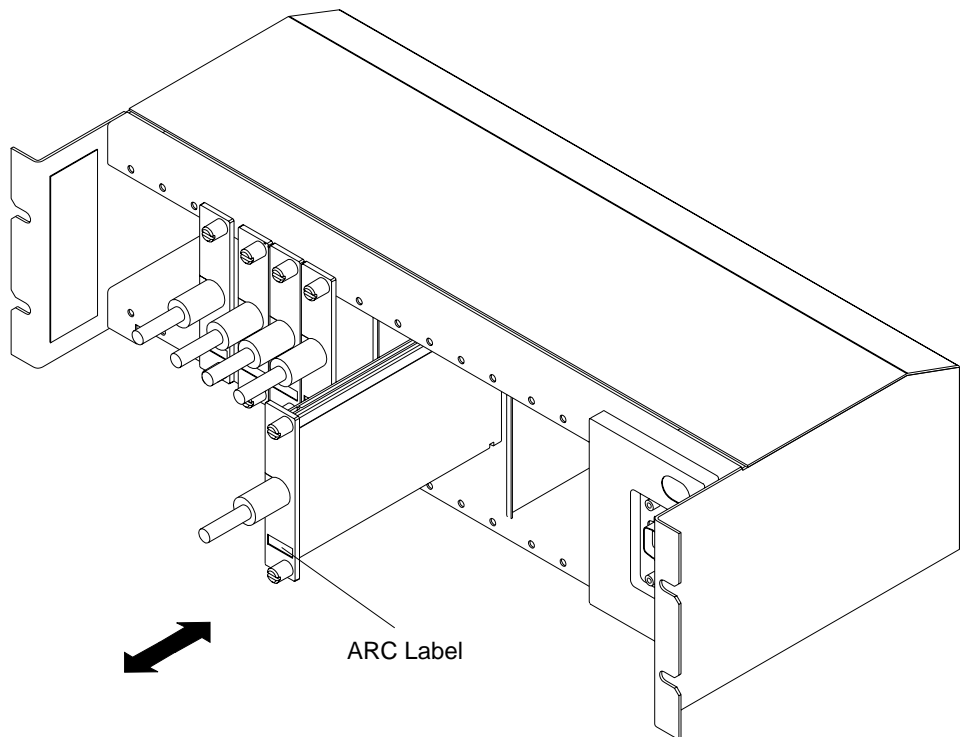

Figure 3-14. ARC Assembly A in an LCB

Step 6 Repeat Steps 2, 4, and 5 for every ARC you want to remove.

If you have no ARC to install, go to Step 17 on page 3-23.

Otherwise, continue with next step to install an ARC.

Step 7 Identify the ARC physical interface type

An ARC cable terminates with one of the following connectors:

- IBM 3745 type
- ITU-T interface type:
 - V.24
 - V.35
 - X.21.

The interface label on the front of the ARC identifies the ITU-T interface type (see Figure 3-15).

Figure 3-15 shows the different types of ARC cable connector.

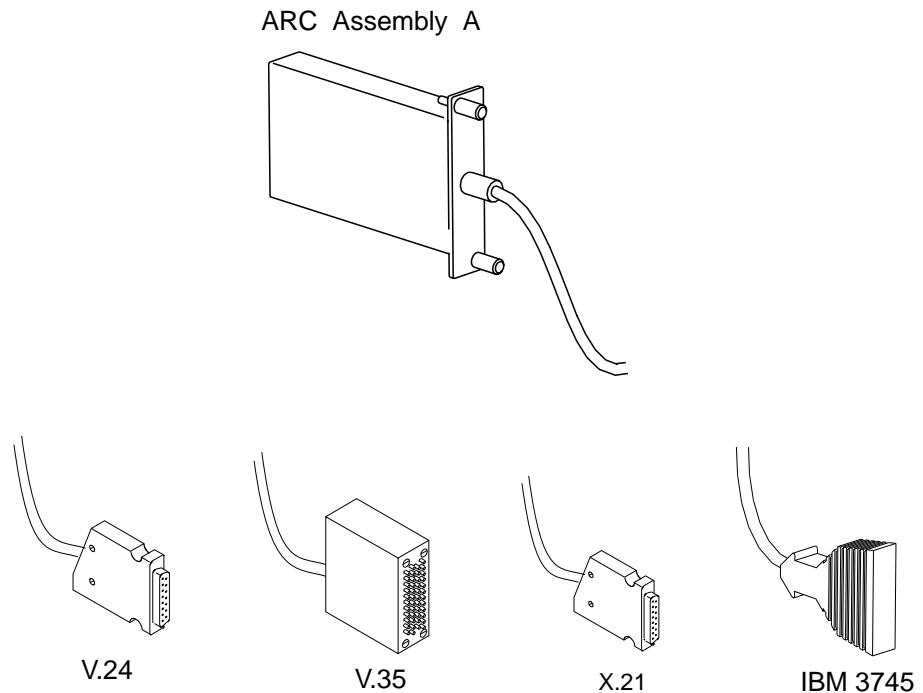

Figure 3-15. The ARC Assembly A and Its Different Types of Connector

Step 8 Label the ARC cable

a. Verify that the following information about each ARC from the plugging sheets is on a pair of ARC labels (part number 63F2505):

- LCB:
 - Number
 - Location
- IBM 3746-900 name
- Range of the LIC 11 addresses.
- Connector slot position (+0 to +14 or +16 to +30)
- Symbolic line name.

- b. Stick the ARC labels at either end of the ARC cable (see **5** in Figure 3-10 on page 3-15). Be sure to remove any old labels first.

Step 9 For each ARC to install, repeat steps 7 and 8.

Step 10 Insert the ARC

Guide rails in the LCB ensure that the ARC is inserted the correct way (with the ARC type label below the cable).

Push the ARC into the LCB until the front of the ARC touches the LCB. Tighten the two retaining screws. Refer to Figure 3-14 on page 3-20.

Step 11 Connect the ARC cable to a DTE or DCE

If you are using a V.24, V.35, or X.21 ARC, plug its cable interface connector into the DTE or DCE connector and tighten the retaining screws.

If you are using an ARC with a 3745 cable connector, plug the ARC cable connector into the connector of the 3745-type cable:

- a. Place the connecting seal on one of the connectors.
- b. Hold a connector in each hand.
- c. Ensure that the pins are correctly aligned with the holes in the female connector, push the two connectors *strongly* together.
- d. When the side levers *click* into place, you have correctly installed the connectors.

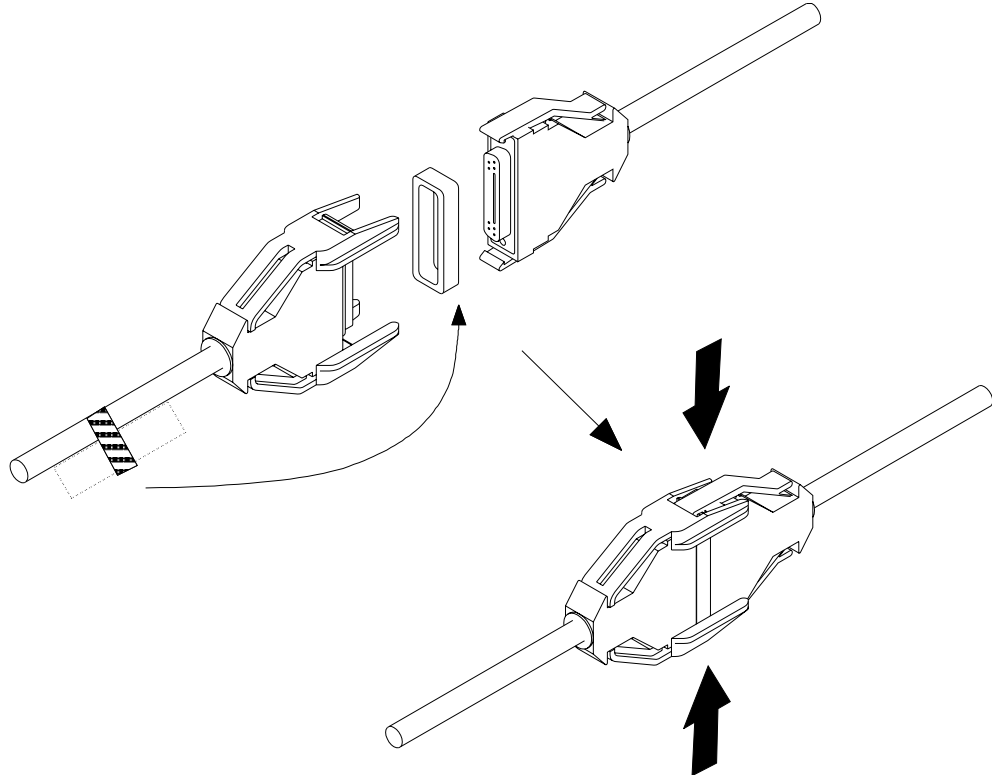

Figure 3-16. IBM 3745-Type Connector

Step 12 For each ARC to be installed, repeat Steps 10 and 11.

Step 13 If you are using a **V.35** connection to a **French modem** , go to Step 14.
If you are using a **V.35** connection to a **French terminal** , go to Step 15.
Otherwise, go to Step 16.

Step 14 If you need to connect a **V.35 DCE ARC cable to a French modem**, connect the V.35 DCE adapter between the ARC cable and the modem:

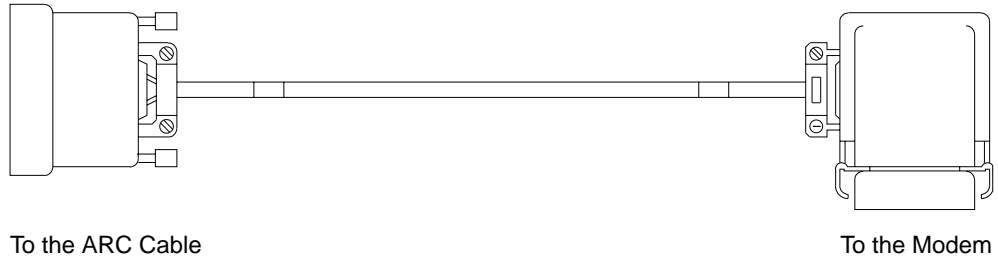

Figure 3-17. French V.35 DCE Adapter

Step 15 If you need to connect a **V.35 DTE ARC cable to a French terminal**, connect the V.35 DTE adapter between the ARC cable and the terminal:

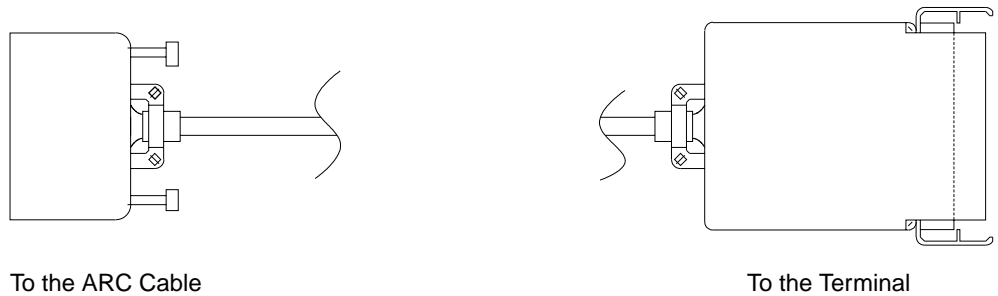

Figure 3-18. French V.35 DTE Adapter

Step 16 Ask the network operator to activate the line of the new or changed ARC. If the activation is not possible, inform the IBM representative.

Step 17 Update the plugging sheets, if necessary.

Step 18 You have finished this procedure.

To integrate the changes that you have made, go to "Updating the Active CDF-E (3746-900 Only)" on page 5-1.

Removing or Installing ARC Assembly B

BEFORE BEGINNING
 Do the "Starting Connection Tasks" on page 3-2 before beginning this task.

Use the following procedure to install or remove the active remote connector assembly B or its cable:

Step 1 Identify the ARC assembly B

The ARC assembly B has a separate cable and is light grey.

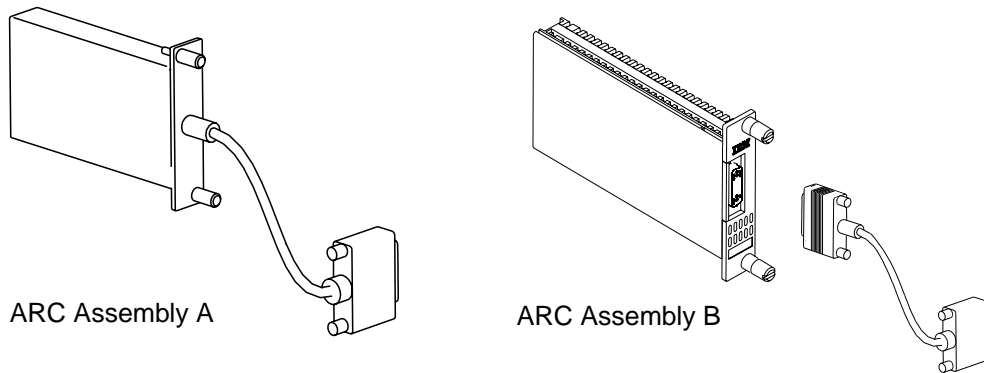
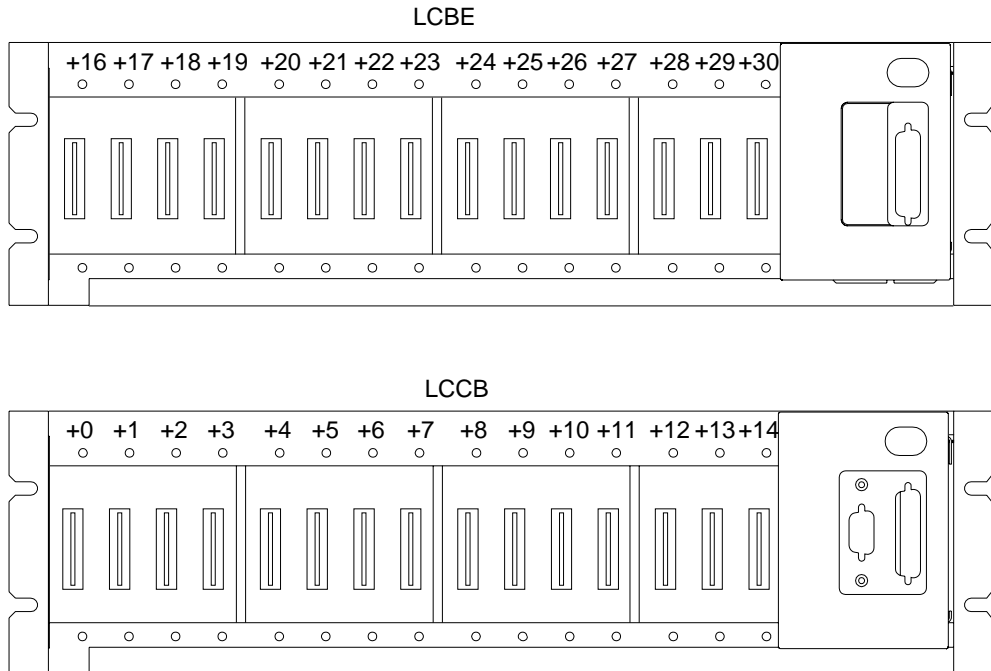

Figure 3-19. ARC Assembly A and B

Step 2 Locate the ARC slot in the line connection box (LCB). An LCB pair, the base (LCBB) and expansion (LCBE), contains a total of 30 slots:



Step 3 If you are only installing an ARC, go to Step 7 on page 3-26.

Otherwise, ask the network operator to deactivate the ARC communication lines that you wish to unplug and:

- If you are only replacing an ARC without changing its cable , replug its cable and go to Step 6 on page 3-26.
- **Otherwise**, continue with the next step.

Step 4 Unplug the ARC cable from the DTE/DCE or the 3745-type connector.

When disconnecting a 3745-type connector:

- a. Hold the connectors with both hands.
- b. With one hand squeeze the side levers and at the same time pull the two connectors apart with side-to-side rocking motion.
- c. Store the connecting seal with the ARC cable for future use.

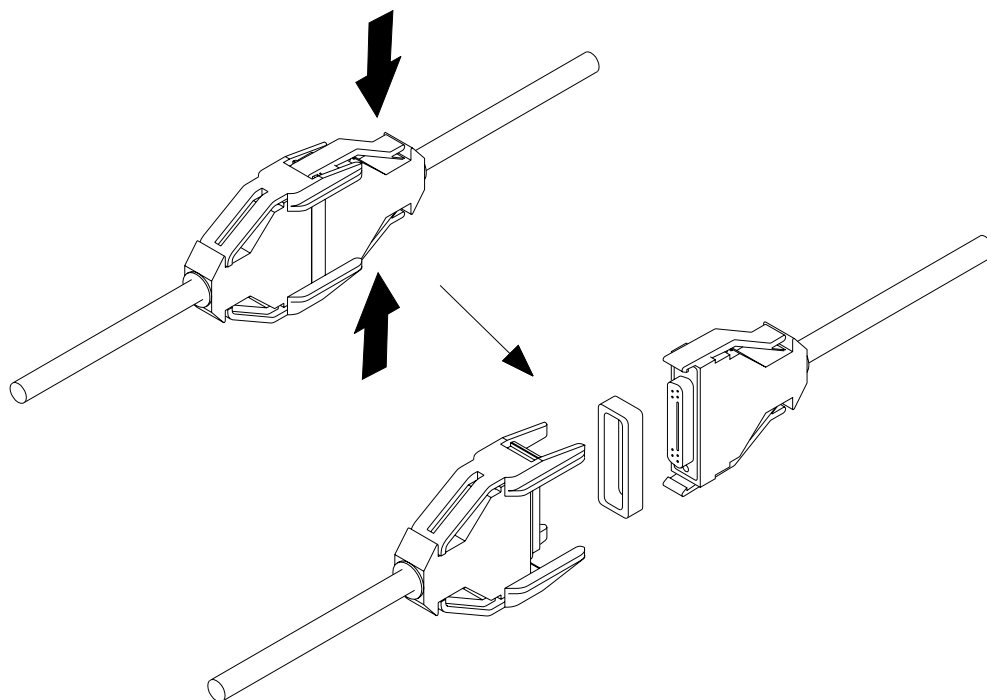

Step 5 Unplug the ARC cable from the ARC.

Unplug one or both ends of the ARC cable, as necessary, for every ARC and cable that you are removing.

If you are only changing an ARC cable without changing its associated ARC, go to Step 9 on page 3-26.

Step 6 Remove an ARC from the LCB

Loosen the retaining screws and pull out the ARC.

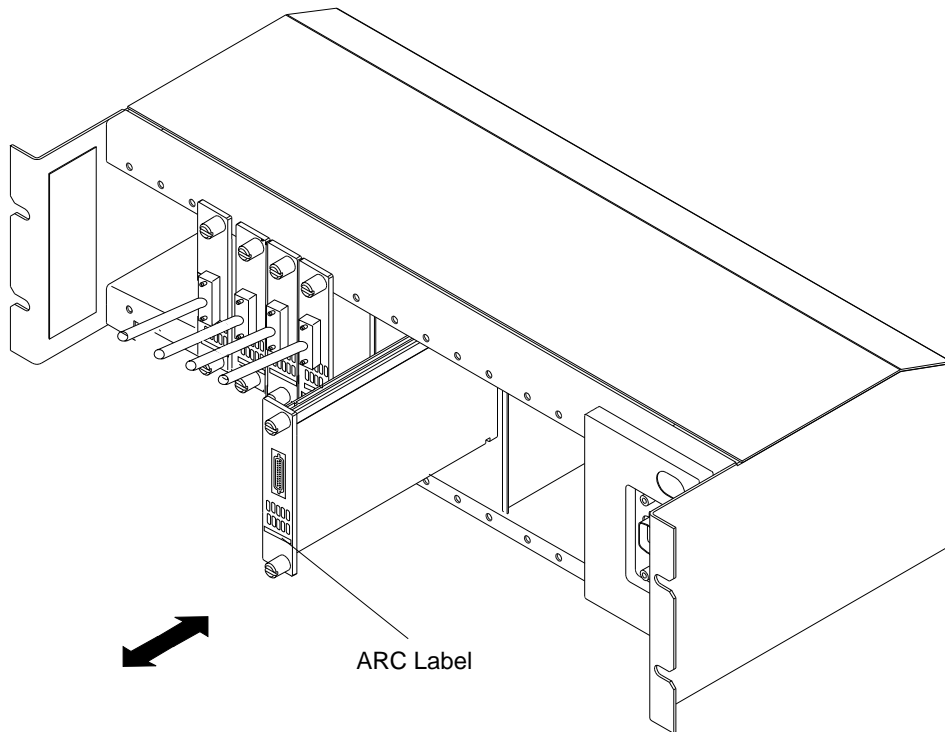

Figure 3-20. ARC Assembly B in an LCB

Repeat this step for every ARC you want to remove.

If you have no ARCs to install, go to Step 17 on page 3-29.

Otherwise, continue with next step to install an ARC.

Step 7 Identify the ARC physical interface type

The label on the front of the ARC identifies its ITU-T interface type.

Step 8 Insert the ARC into the LCB.

Guide rails in the LCB ensure that the ARC is inserted correctly (with the ARC type label below the cable connector).

Push the ARC into the LCB until the front of the ARC touches the LCB. Tighten the two retaining screws. Refer to Figure 3-20.

For each ARC to install, repeat Steps 7 and 8.

If you are only changing an ARC without changing its associated cable, go to Step 15 on page 3-29.

Otherwise, continue with the next step.

Step 9 Identify the ARC cable

The ARC has a separate cable which has a connector that corresponds to the physical interface type of the ARC:

- An ARC cable terminates with one of the following connectors:
 - IBM 3745 type

- ITU-T interface type:
 - V.24
 - V.35
 - X.21.
- The ARC is connected to either a DTE or DCE.
- The cables are available in a range of cable lengths (for further details of available cable lengths, refer to the *Migration and Planning Guide*, GA33-0183).

Figure 3-21 shows the different types of ARC cable connectors.

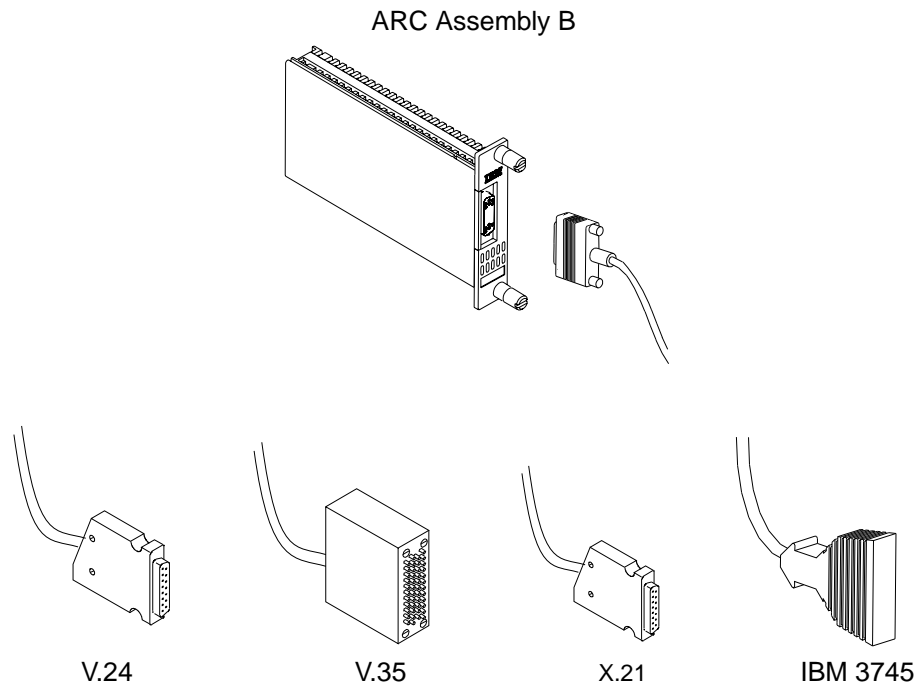

Figure 3-21. The ARC Assembly B and Its Different Types of Connector

Select the ARC cable that has a label that corresponds to the line needs:

- ITU-T interface type
- Destination (DTE or DCE)
- Length.

Step 10 Label an ARC cable

- a. Verify that the following information about each ARC from the plugging sheets is on a pair of ARC cable labels (part number 63F2505):
 - LCB:
 - Number
 - Location
 - IBM 3746-900 name
 - Range of the LIC 11 addresses.
 - Connector slot position (+0 to +14 or +16 to +30)
 - Symbolic line name.

- b. Stick these labels at both end of the ARC cable (see **5** in Figure 3-10 on page 3-15). Be sure to remove any old labels first.

Step 11 Connect the ARC cable to the DTE or DCE

- If you are using an ARC V.24, V.35, or X.21, plug its cable interface connector into the DTE or DCE connector and tighten the retaining screws.
- If you are using an ARC cable that has 3745 connector, plug it into the connector of the 3745-type cable:
 - a. Place the connecting seal on one of the connectors.
 - b. Hold a connector in each hand.
 - c. Ensure that the pins are correctly aligned with the holes in the female connector. Push the two connectors *strongly* together.
 - d. When the side levers *click* into place, you have correctly installed the connectors.

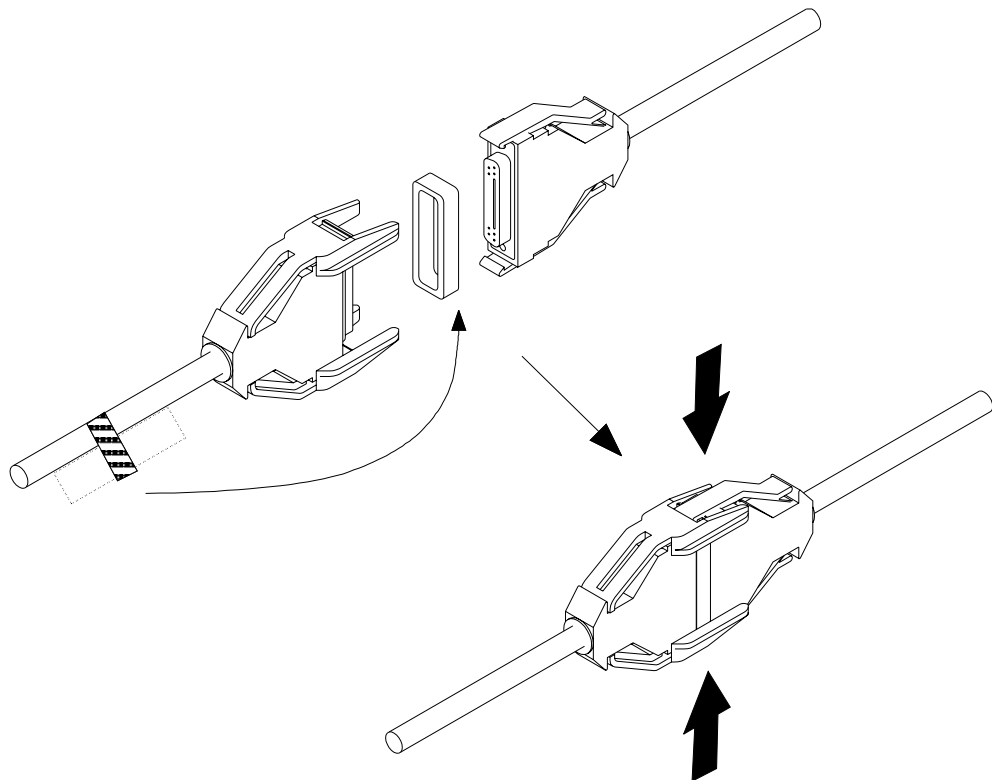

Figure 3-22. IBM 3745-type Connector

Step 12 If you are using a **V.35** connection to a **French modem** , go to Step 13 on page 3-29.

If you are using a **V.35** connection to a **French terminal** , go to Step 14 on page 3-29.

Otherwise, go to Step 15 on page 3-29.

Step 13 If you need to connect a **V.35 DCE ARC cable to a French modem**, connect the V.35 DCE adapter between the ARC cable and the modem:



Figure 3-23. French V.35 DCE Adapter

Step 14 If you need to connect a **V.35 DTE ARC cable to a French terminal**, connect the V.35 DTE adapter between the ARC cable and the terminal:



Figure 3-24. French V.35 DTE Adapter

Step 15 Connect the ARC cable to its associated ARC.

Because of the shape of the connector, it can not be installed incorrectly.

For each ARC cable that you wish to install, repeat Steps 9 through 15.

Step 16 Ask the network operator to activate the line of the new or changed ARC cable. If the activation is not possible, inform the IBM representative.

Step 17 Update the plugging sheets, if necessary.

Step 18 You have finished this procedure.

To integrate the changes that you have made, go to "Updating the Active CDF-E (3746-900 Only)" on page 5-1.

Part 2. Integrating

This part explains the procedures used to integrate hardware and software configuration changes into your network. It contains two chapters:

- Chapter 4, "Starting the 3745 Integration," guides you through the following chapters according to your present task.
- Chapter 5, "Integration Procedures":
 - Has an introduction to MOSS-E use for integrating changes in the:
 - MOSS
 - MOSS-E
 - service processor
 - and 3746-900.

Some of these are:

- Changing the MOSS-E and DCAF passwords
- Verifying that the hardware (LIC types 11, 12, and 16, LCBs, and ARCs) changes have been recognized by the MOSS-E
- Modifying and saving the configuration data file - extended (CDF-E).
- Gives the procedures for using the MOSS functions for integrating changes in the 3745 base frame. Some of these are:
 - Changing passwords, if you do not have a Model A
 - Modifying the configuration data file (CDF)
 - Backing up the MOSS hard disk.

Note: Before using the procedures in Chapter 5, the 3745 (and 3746-900, if you have one) must be powered ON.

Chapter 4. Starting the 3745 Integration

The 3745 runs under the control of the Network Control Program (NCP). Any configuration changes that you make must be known to NCP. You use the MOSS (or the MOSS-E, if you have it) to inform the NCP of hardware changes through the MOSS configuration data file (CDF) and the MOSS-E configuration data file - extended (CDF-E).

These procedures are performed at **initial** installation and during **later** modifications of your 3745.

Initial installation refers to the first installation of your 3745 or its re-installation after moving the communication controller. This is done with the help of the IBM service representative.

Later modifications refer to changes made at any other time. These later modifications do not always require a service representative to be present.

Starting Procedure

The following procedure guides you through the remaining chapters according to the tasks that you want to accomplish.

Note: Always save the new configuration (the CDF and CDF-E) on a diskette when you make changes in the MOSS or MOSS-E.

Step 1

Are you integrating a Model A (which may have a 3746-900 attached)?	
Yes	Go to Step 2.
No	Go to Step 4 on page 4-2.

Step 2

Is this the initial installation?		
Yes	Go to "MOSS-E Integration Functions (3746-900 Only)" on page 5-1	
No	Have you made changes in the 3746-900 (cables, LCBs, or ARCs)?	
	Yes	Go to "Updating the Active CDF-E (3746-900 Only)" on page 5-1.
	No	Go to Step 3.

Step 3

Are you making changes in the configuration of the service processor or MOSS-E?	
Yes	Select the function(s) that you need from the Service Processor menu. Refer to the <i>Basic Operations Guide</i> , SA33-0177.
No	Go to Step 5 on page 4-2.

Step 4

Is this the initial installation?	
Yes	Go to "MOSS Integration Procedures" on page 5-5.
No	Go to Step 5.

Step 5

Do you want testing or operating information about a LIC type 5 or 6?	
Yes	Refer to the <i>LIC5/6 Migration and Integration Guide, SA33-0416</i> .
No	Select the function(s) or procedure(s) that you need in "MOSS Integration Procedures" on page 5-5 to make changes in the 3745 frame, and the MOSS.

Chapter 5. Integration Procedures

MOSS-E Integration Functions (3746-900 Only)

Use the MOSS-E (running on the service processor) to integrate the hardware connection changes you made to the 3746-900.

To log on and navigate in the MOSS-E functions refer to the *Basic Operations Guide*, SA33-0177.

There is on-line help to guide you through the MOSS-E functions.

Initial Installation

Provide the service representative with your planning worksheets from the *Migration and Planning Guide*, GA33-0183.

When the IBM service representatives have finished installing or upgrading your controller:

- You may change the MOSS-E passwords yourself using the **Manage Passwords** function which is in the **Operation Management** task of the **Service Processor** menu. For more information refer to the *Basic Operations Guide*, SA33-0177. The default is the same for all passwords: IBM3745.
- If you have controlling workstations to remotely access the service processor, you may change the IBM Distributed Console Access Facility (DCAF) program password. This is the password that a DCAF remote console operator must use to connect to the service processor.

To change this password use the MOSS-E function **Customize DCAF Target Settings** which is in the **Configuration Management** task of the **Service Processor** menu. For more information refer to the *Console Setup Guide*, SA33-0158.

- To receive regular and periodic microcode updates from RETAIN* use the MOSS-E function **Set Automatic Microcode Download Option** which is in the Service Processor **Change Management** menu.

When you have finished the MOSS-E part of the integration go to "MOSS Integration Procedures" on page 5-5.

Updating the Active CDF-E (3746-900 Only)

When changes have been made in your controller hardware configuration, especially to the lines connected to a LIC 11 (adding or changing LCBs or ARCs), use the following procedure to:

- Verify that these resources have been (automatically) taken into account.
- Identify them with character strings of your choice.
- Save the active configuration (CDF-E) as the reference CDF-E.
- Back up the active CDF-E to optical disk.

Step 1 Double-click on the 3746-900 object icon or on 3746-9x0 Menu in the window list.

Step 2 Click once on **Configuration Management** task, then twice on **Display/Update Active Configuration (CDF-E)** function.

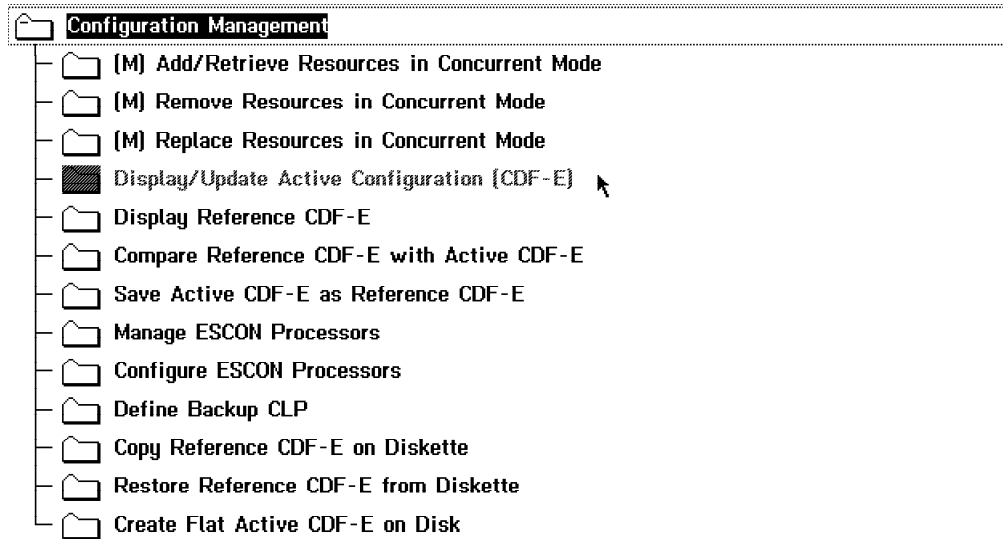

Step 3 Verify the presence of the LCBs and ARCs that you just added or changed for each CLP.

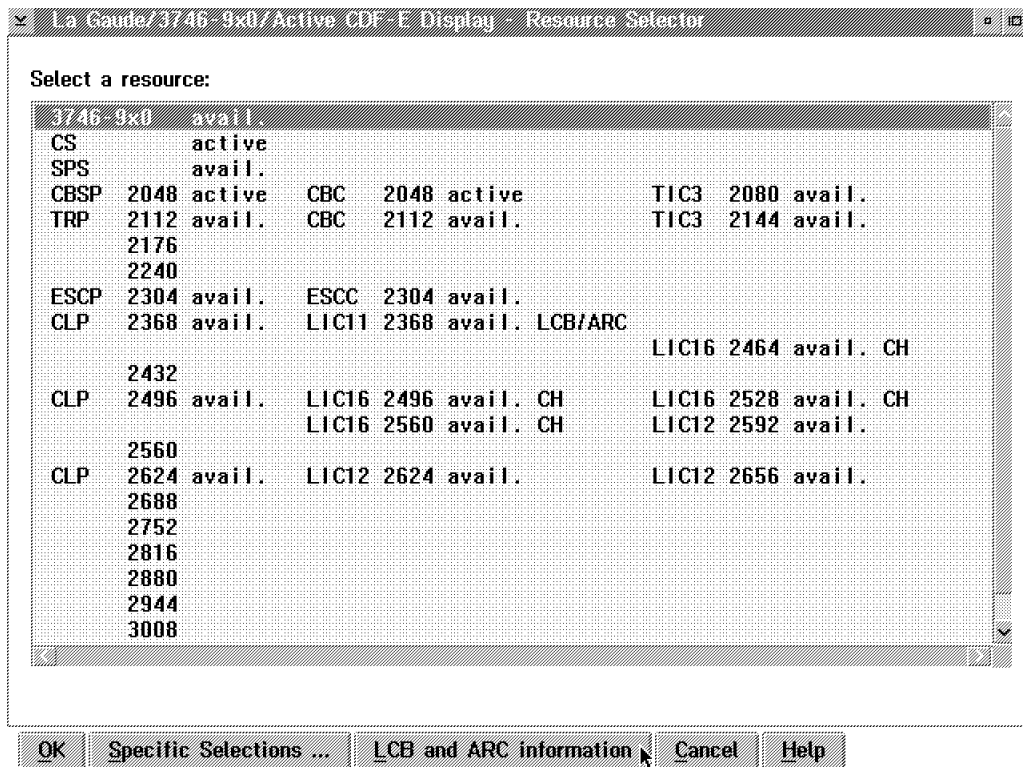

Notes:

- a. When an LCB with ARC is detected, **LCB/ARC** is displayed on the right side of the associated LIC 11.
- b. If there is no ARCs installed, only **LCBB** is displayed.
- c. If you have installed an LCBE without any ARCs, the LCBE is not displayed until its adapter is IMLed or an ARC is installed into the LCBE.

Step 4 Click on **LCB and ARC information**.

Step 5 To select an:

LCBB: Click on the line of the LIC 11 associated with the LCBs and ARCs that you have been working with.

LCBE: Click on the line just below its associated CLP.

CLP address	LIC type	LCB type	LCB Number / Location
CLP 2368 avail.	LIC11 2368	LCBB	
	LIC16 2464	LCBE	
CLP 2496 avail.	LIC16 2496		
	LIC16 2528		
	LIC16 2560		
	LIC12 2592		
CLP 2624 avail.	LIC12 2624		
	LIC12 2656		

Step 6 Enter or update the **LCB Number / Location** field for the LCB. This information should be on the plugging sheets from the *Migration and Planning Guide*, GA33-0183.

You may enter up to 25 alphanumeric characters to help you identify the LCB attached to this processor.

To verify and identify any other LCBs you added or changed, press **Enter** and repeat Steps 5 and 6 for each LCB.

Step 7 When finished with all the LCBs, click on **Save**.

- Step 8** When the Save is finished, click on **OK**.
- Step 9** If you have ARCs attached to an LCB, select the LCB and click on . Otherwise, go to Step 15.
- Step 10** Select an ARC, then enter or update the **Symbolic line name** field. This information should be on the plugging sheet.
- You may enter up to 8 alphanumeric characters to help you identify the ARC.

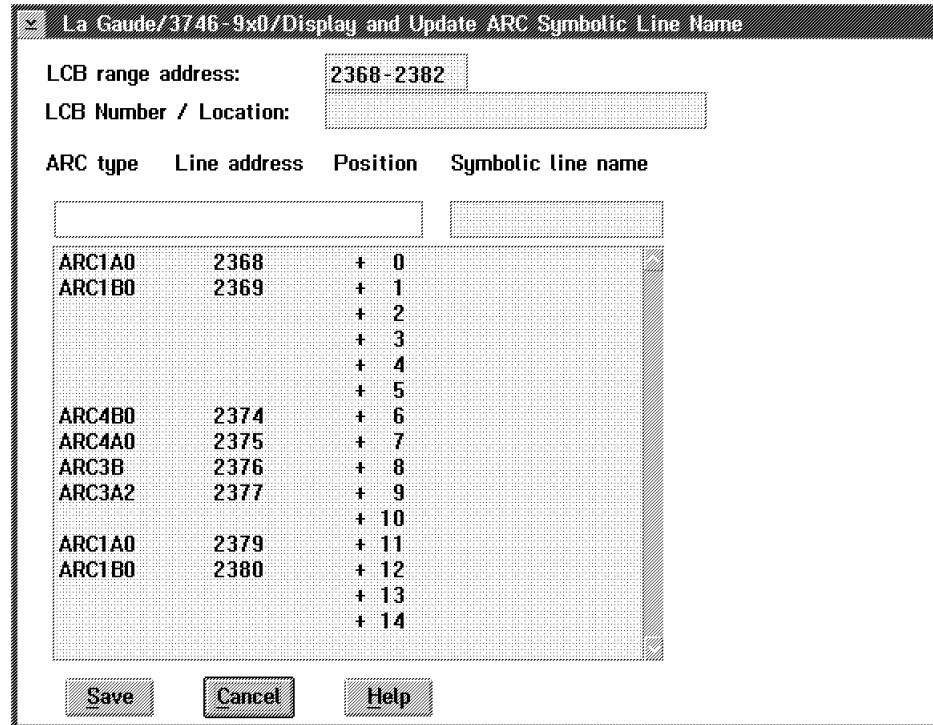

La Gaude/3746-9x0/Display and Update ARC Symbolic Line Name

LCB range address: 2368-2382

LCB Number / Location:

ARC type	Line address	Position	Symbolic line name
ARC1A0	2368	+ 0	
ARC1B0	2369	+ 1	
		+ 2	
		+ 3	
		+ 4	
		+ 5	
ARC4B0	2374	+ 6	
ARC4A0	2375	+ 7	
ARC3B	2376	+ 8	
ARC3A2	2377	+ 9	
		+ 10	
ARC1A0	2379	+ 11	
ARC1B0	2380	+ 12	
		+ 13	
		+ 14	

Save Cancel Help

- Step 11** To verify and identify any other ARCs you added or changed, press **Enter** and repeat Steps 5 to 11 for each ARC.
- Step 12** When finished with all the ARCs attached to this LCB, click on .
- Step 13** When the Save is completed, click on **OK**.
- Step 14** To verify and identify ARCs on other LCBs, repeat Steps 10 and 11 for each LCB.
- Step 15** When you have verified all the LCBs and ARCs, click on **Cancel** to exit from the function.
- Step 16** Double-click on the **Save Active CDF-E as Reference CDF-E** function.
- Step 17** When the Save is finished, click on **OK**.

At this step IBM recommends saving the CDF-E on the optical disk (refer to the *Basic Operations Guide*, SA33-0177).

Saving the Controller Configuration

IBM **recommends** using your BACKUP optical disk to save the current configuration of the controller in the MOSS-E after a CDF-E update has been done.

Note: No need to save controller configuration in case of network change for the Ethernet Bridge or the Multiaccess Enclosure.

To backup the controller configuration:

- Step 1.** Insert the backup optical diskette into the optical drive.
- Step 2.** Double-click on the **Service Processor object icon** or on the Service Processor Menu in the Window List.
- Step 3.** Click on **Operation Management**.
- Step 4.** Double-click on **Manage Disks and Databases** function.
- Step 5.** Click on **Save Databases on Optical Disk**.
- Step 6.** Click on **OK**.
- Step 7.** Follow the prompts (the active CDF-E is being copied on the hard disk and then onto the optical disk).
- Step 8.** When the save is completed, click on **Cancel** to exit from the function.

This operation takes about **5 minutes** and does not disturb the service processor operation.

MOSS Integration Procedures

Following are the procedures necessary to accomplish the task of integrating the 3745 base frame hardware into your network using the MOSS.

All of these procedures are explained in more detail as functions in the *Advanced Operations Guide*, SA33-0097.

If you have a 3745 Model A

- 1. Log on the service processor
- 2. Open a MOSS window

Refer to the *Basic Operations Guide*, SA33-0177, for detailed operations

On the MOSS function screens you are often asked to press **Entr**. This means press on the service processor keyboard.

Integrating an Initial Installation

When the service representative asks you, perform the following required procedures:

1. "Upgrade Procedure" on page 5-8
2. "Updating Link IPL Ports" on page 5-17 if you have a link-attached 3745
3. "Saving MOSS from Fixed Disk onto Diskettes" on page 5-19. This procedure is performed after all other required and optional procedures.

You may perform the following optional procedures anytime before "Saving MOSS from Fixed Disk onto Diskettes":

1. "Changing Passwords on the 3745 MOSS" on page 5-14
2. "Setting Power On Schedule" on page 5-16.

Perform "Putting the MOSS On-Line" on page 5-21 whenever needed.

Notes:

1. The integration procedure (LIC types 1-4) must be performed in disk mode because it uses MOSS functions, which are not available in diskette mode.
2. If you want to change the operating mode of a 3745 Model 410 or 610 (twin CCUs) refer to the CDF-CCU operating mode function in the *Advanced Operations Guide, SA33-0097*. Perform the appropriate procedure before saving the fixed disk onto diskettes.





Integrating a Later Modification

Perform the appropriate procedures in the rest of this chapter that apply to your 3745 installation. After you have completed your modification, perform a backup of the 3745 fixed disk. See "Saving MOSS from Fixed Disk onto Diskettes" on page 5-19.

Note:

- When reconfiguring LICs, ensure that the total weight of lines connected to a low-speed scanner is within the scanner capacity.
- To calculate them see Appendix A, "LSS Characteristics and Line Weights."

Conventions Used in this Chapter for the MOSS

Symbols for the Keys: When you see a keyboard symbol, press and release the corresponding key. For example,     means you must press and release the **C** key, the **S** key, the **R** key, and then the **Enter** key in, that order.

Messages Displayed: They are shown like this:

CDF UPGRADE COMPLETED

Upgrading or Updating CDF

There are two related procedures that use the MOSS CDF function to change the data in the configuration data file (CDF):

- CDF Upgrade

This procedure causes the CDF to record **all hardware** changes that you are making to the telecommunication lines connecting to the 3745. These include LICs and cable changes for LICs, token-ring adapters (TRA), and high speed scanners (HSS).

Note: The Upgrade function is disruptive. While using it, all lines attached to the CCU that is being upgraded have to be taken out of operation for 15 minutes and the control program must be re-loaded.

- CDF Update

This procedure causes the CDF to record **certain hardware** changes that you are making to the telecommunication lines connecting to the 3745.

It also **displays** or **modifies** the telecommunication **line parameters**.

When to Use Upgrade or Update

Not Always Necessary

It is not always necessary to change the CDF:

- If you remove or install an **Ethernet LAN AUI cable**, no CDF change is necessary.
- Another example is if you replace a LIC by a spare LIC of the same type, and do not change the line configuration. If you are unsure, use the Display/Update CDF procedure, and verify the actual configuration.

At Initial Installation

First perform an Upgrade for the **hardware** changes, then, if you want to verify or change the **line parameters**, perform an Update.

During a Later Modification

If you want to display or modify **line parameters**, perform an Update.

If you have made **TRA cable change**, perform an Upgrade.

If you have made **other hardware changes**, you can use either Upgrade or Update depending on the changes you made. In general, use Update for a small number of hardware changes; use Upgrade for many changes, but:

- If the MOSS is not alone, you can use Update to record hardware changes without halting your system. You can at the same time make line parameter changes.

The only disadvantage is the time it takes to enter each hardware change and the possibility of errors during data entry.

- If you can stop your system approximately 15 minutes, use Upgrade. The hardware changes are put into the CDF automatically, quickly, and are less error prone.

The following table compares the two procedures:

Upgrade Procedure	Update Procedure
<ul style="list-style-type: none"> • Is disruptive at CCU level • Control program removed • MOSS must be alone • Modifies the CDF to record hardware changes when: <ul style="list-style-type: none"> – Changing a LIC – Changing a LIC cable – Changing a TRA cable – Changing an HSS cable. 	<ul style="list-style-type: none"> • Is disruptive only for the concerned scanners • Control program remains active • MOSS must be on-line • Modifies the CDF to record hardware changes when: <ul style="list-style-type: none"> – Changing a LIC – Changing a LIC cable – Changing an HSS cable. • Displays LIC, HSS, TRA, and Ethernet LAN adapters (ELA) line parameters and LIC information • Modifies LIC and HSS line parameters.

For more help, refer to the CDF function in the *Advanced Operations Guide*, SA33-0097.

Upgrade Procedure

- If the MOSS is already **running alone** (the CCU control program is not operational), begin at Step 8 on page 5-9.
- If the MOSS is **not running alone**, then you must use the reset (RST) MOSS function to remove the control program from the CCU(s):

For a Model 410,41A, 610, or 61A, begin at Step 1.

For the other models, begin at Step 7.

Step 1

Step 2 Select the CCU affected.
 or then

Step 3

Step 4

If the MOSS is alone on the second CCU, go to Step 8 on page 5-9.

Otherwise, continue with the next step.

Step 5 Select the second CCU.
 or then

Step 6

Step 7

Step 8

Step 9 To start the upgrade:

Step 10 Wait until one of these messages is displayed:

- CDF UPGRADE COMPLETED
This means that all of the power supplies are functioning, go to Step 13.
- SOME INSTALLED POWER SUPPLIES ARE NOT UP
This means that not all of the power supplies are functioning, continue with the next step.

Step 11 Confirm or cancel the upgrade. If you confirm the upgrade, any power supplies not functioning are considered as not installed, and any lines depending on that power supply cannot be upgraded.

To confirm:

and go to Step 13.

To cancel:

and continue with the next step.

Step 12 If you want to perform the MOSS power services (POS) function:

and, if necessary, refer to POS in the *Advanced Operations Guide*, SA33-0097. After performing the POS, return to Step 8 to repeat the CDF upgrade.

Otherwise, continue with the next step.

Step 13

If you want to change any line parameters, go to "Update Procedure" on page 5-10.

Otherwise, continue with the next step.

Step 14

Step 15 If you have a dual CCU controller:

or or then or then

Otherwise, continue with the next step.

Step 16 or then

If you are loading the control program from the 3745 fixed disk (using the MOSS DII function), go to Step 19.

Otherwise, continue with the next step.

Step 17 When the IPL has completed phase 4, the following message is displayed for each CCU undergoing IPL:

IPL PHASE 4 ENABLED CA xxx...

If other messages appear or the letter U appears anywhere after CA, refer to the *Basic Operations Guide*, SA33-0177, for an explanation.

Step 18 Call the host operator and ask for the control program(s) to be loaded into your communication controller. Let the IPL continue, no additional 3745 operator action is required.

Step 19 When the IPL is finished, the following message is displayed once for each CCU undergoing IPL:

IPL COMPLETE

If other messages appear, refer to the *Basic Operations Guide*, SA33-0177, for an explanation.

Otherwise, continue with other integration procedures.

Note: You must do "Saving MOSS from Fixed Disk onto Diskettes" on page 5-19 when you have finished all other integration procedures.

Update Procedure

The following is necessary to use the Update function:

- Up-to-date plugging sheets for the modifications that you are making.
- The lines being updated must have been defined at control program generation time (SYSGEN).
- When updating the cable information for an HSS line, the appropriate line(s) must be deactivated.
- The MOSS must be on-line.
 1. If MOSS is **alone**, begin at Step 1.
 2. If MOSS is **off-line**, and you have a dual CCU 3745 begin at Step 7 on page 5-11.
 3. If MOSS is **off-line**, and you have a single CCU 3745 begin at Step 14 on page 5-11.
 4. If MOSS is **on-line**, begin at Step 15 on page 5-11.

Step 1

Step 2 If you have a dual CCU controller:

or or then or then

Otherwise, continue with the next step.

Step 3 or then

If you are loading the control program from the 3745 fixed disk (using the MOSS DII function), go to Step 6 on page 5-11.

Otherwise, continue with the next step.

Step 4 When the IPL has completed phase 4, the following message is displayed for each CCU undergoing IPL:

IPL PHASE 4 ENABLED CA xxx...

If other messages appear or the letter U appears anywhere after CA, refer to the *Basic Operations Guide*, SA33-0177, for an explanation.

Step 5 Call the host operator and ask for the control program(s) to be loaded into your communication controller. Let the IPL continue, no additional 3745 operator action is required.

Step 6 When the IPL is finished, the following message is displayed once for each CCU undergoing IPL:

IPL COMPLETE

If other messages appear, refer to the *Basic Operations Guide*, SA33-0177, for an explanation.

Go to Step 15.

Step 7

Step 8 Select CCU A.

then

Step 9

Step 10

When this message is displayed:

MOSS-ONLINE

continue with the next step.

Step 11

Step 12 Select CCU B.

then

Step 13

Step 14

When this message is displayed:

MOSS-ONLINE

continue with the next Step

Step 15

Step 16

Step 17 Enter the port number xxx:

Step 18 Write down the line adapter (LA) number and type for each line adapter to be displayed or updated.

Step 19

Step 20

Step 21 Enter the LA number (1 through 32):

If the type of line adapter displayed is:

- TSS (a LIC), then to display or update the information for that line adapter, go to Step 23.
- HSS, then to display or update the information for that line adapter, go to Step 27 on page 5-13.
- ELA or TRA, then you can only display the information for that line adapter. Continue with the next step.

Step 22 When you have finished with the ELA or TRA display, to display or update another line adapter:

Repeat Step 21

Otherwise:

You have finished this procedure. Continue with other integration procedures.

Step 23 If you want to:

- Only display more TSS (LIC) information, without making any changes on this screen:

Repeat Step 21

- Save any connection changes made:

Continue with the next step.

- Quit this procedure without saving any changes you may have made:

You have finished this procedure, do no more Steps. Continue with other integration procedures.

Note: You must at least do "Saving MOSS from Fixed Disk onto Diskettes" on page 5-19 when you have finished all other integration procedures.

Step 24 Select an option:

or or

Note: Use the REPLACE LIC option, if you:

- Removed a LIC and then installed a different type of LIC in the same slot
- Changed a LIC cable.

Step 25 Enter the LIC position number from the plugging sheet:

Wait until you get the message:

CDF LIC CHANGE COMPLETED

.

Step 26 If you want to:

- Display or update more LIC information, return to Step 21 on page 5-12.
- Continue the update without making any more changes, go to Step 30 on page 5-14.
- Quit this procedure without saving any changes you may have made:

You have finished this procedure, do no more Steps. Continue with other integration procedures.

Note: You must do "Saving MOSS from Fixed Disk onto Diskettes" on page 5-19 when you have finished all other integration procedures.

Step 27

and select one of the following:

- To update the HSS line parameters:

- To update the HSS cable information:

- To make no changes, continue with the next step.

Step 28 Press

repeatedly until you reach the screen:

CDF DISPLAY/UPDATE: LINE ADAPTERS

Step 29 Repeat Steps 21 to 28 for each HSS to be displayed or updated.

Step 30

If you are integrating hardware or line parameter changes, continue with the next step.

Otherwise, you have finished this procedure, do no more Steps. Continue with other integration procedures.

Note: You must at least do "Saving MOSS from Fixed Disk onto Diskettes" on page 5-19 when you have finished all other integration procedures.

Changing Passwords on the 3745 MOSS

If you have a 3745 Model A

Do not use this procedure.
Refer to "Initial Installation" on page 5-1

This procedure covers the following MOSS password functions:

1. Update management password
2. Update local console password
3. Update remote console password
4. Update maintenance password
5. Display passwords.

For information on the remaining password functions see the *Advanced Operations Guide*, SA33-0097. These other functions are:

- Temporary activation of maintenance password
- Permanent activation of maintenance password
- Deactivation of maintenance password
- Display/reset/update log on attempt counters
- Update customer identification
- Update time out for remote console disconnection.

Note: **IBM3745** is the default password for all the 3745s.

When **PASSWORD** appears in the text of the procedure, enter the appropriate current password at the console.

Step 1

Step 2 Type in **your management password** and press
(Or the default management password at first time)

IMPORTANT

Record and safeguard your management password. Loss of this password requires the help of your IBM service representative and is time-consuming. Then, any data not saved on your backup diskettes will be lost in the process.

- Step 3** If you only want to see the passwords without changing them:

Otherwise, go to Step 5.
- Step 4**
- Step 5** If you want to change a non-maintenance password:
 or or then
Continue with the next step.
Otherwise, go to Step 13 on page 5-16.
- Step 6** A password consists of five to eight alphanumeric characters. Do not use blanks. Enter the new password and keep a record of it:
Type in **your password** and press
If you make a mistake, you see an error message. You can try again on the same screen. Refer to the *Advanced Operations Guide*, SA33-0097, for a description of error messages.
- Step 7**
- Step 8** Repeat Steps 5 to 7 for each non-maintenance password to be changed.
- Step 9** If you want to change the maintenance password:
Continue with the next step.
Otherwise, go to Step 13.
- Step 10** A password consists of five to eight alphanumeric characters. Do not use blanks. Enter the new maintenance password and keep a record of it:
Type in **your password** and press
If you make a mistake, you see an error message. You can try again on the same screen. Refer to the *Advanced Operations Guide*, SA33-0097, for a description of error messages.
- Step 11** If you want to choose the Modem Transmission Mode for RSF console:

Otherwise, go to Step 13 on page 5-16.

Step 12 The two options are:

- F** Selects the modem clock: 1200 bps or 2400 bps (for U.S.A. and Canada only)
- H** Selects the MOSS clock: 1200 bps only.

Do either:

or then

Step 13

You have finished this procedure, continue with other integration procedures.

Note: You must at least do "Saving MOSS from Fixed Disk onto Diskettes" on page 5-19 when you have finished all other integration procedures.

Setting Power On Schedule

Step 1

Step 2

Step 3 Enter the time (hours and minutes) next to each day of the week. Use 24-hour notation that includes two digits for the hours, two digits for the minutes, and a colon between these numbers (for example, 00:15, 06:05, or 17:00).

Step 4

Step 5 When you see this message:
DATA SUCCESSFULLY TRANSMITTED

then:

Step 6 You have finished this procedure, continue with other integration procedures.

Note: You must at least do "Saving MOSS from Fixed Disk onto Diskettes" on page 5-19 then you have finished all other integration procedures.

IMPORTANT

The power-on schedule is only active when the Power Control display on the control panel shows the number 2 (for network control).

To set the power-on schedule active, at the IBM 3745 control panel:

Step 1 Press **Power Control** repeatedly until the number **2** appears (blinking) as the sixth digit in the display.

Step 2 Press **Validate**.

Updating Link IPL Ports

The LKP function used in this procedure does not handle link IPL ports using parallel channel adapters (CAs) nor serial channel adapters (ESCON*). For CAs, use the CDF function (refer to the *Advanced Operations Guide*, SA33-0097). For ESCONs, use the MOSS-E functions (refer to the *Basic Operations Guide*, SA33-0177).

IPL Ports on 3745 (All Models)

Step 1

Step 2 If you have a two-CCU machine in twin-dual or twin backup mode, you must select:

or then

Step 3 Select an option numbered 1 through 8 to access the information for one of the eight possible IPL ports. (Line numbers for the defined link IPL ports appear near the bottom of this screen.) Then:

Step 4 If you only want to display the IPL port information:

If you **do not want to** define, modify, or delete IPL port information, go to Step 7.

If you **want to delete** IPL port information, go to Step 6.

Otherwise, continue with the next step.

Step 5 If you want to define or modify the IPL port information, enter the four-digit line number. (The line numbers are shown on the plugging sheets.)

Choose the clock type (E for external or D for direct-attached clock):

or then

Enter options as needed, then:

Then go to Step 7.

Otherwise, continue with the next step.

Step 6 If you want to delete the Link IPL port information, use the space bar to enter four blanks to erase the line number. Then:

If you delete or not, continue with the next step.

Step 7

Repeat Steps 3 to 7 for each Link IPL port to be displayed, defined, or deleted.

When you have finished, continue with the next step.

Step 8 .

You must perform an IPL for these changes to take effect. You can either:

- Perform an IPL (see page 5-18)
- Continue with other integration procedures and perform an IPL later on.

You have finished this procedure.

Note: You must at least do “Saving MOSS from Fixed Disk onto Diskettes” on page 5-19 when you have finished all other integration procedures.

Link IPL Ports on 3746-900.

3746-900

Up to microcode EC D22513, to use an ESCON channel as an IPL port:

1. Click on **Configuration Management** in the MOSS-E menu
2. Double-click on **Manage ESCON Processors**.

From microcode EC D22560, when the APPN feature **is not** installed, to use an ESCON channel as an IPL port:

1. Click on **Configuration Management** in the MOSS-E menu
2. Double-click on **Configure ESCON Processors**.

3746-900NN and 3746-900IP

From microcode EC D22560, when the APPN feature **is** installed, to use an ESCON channel as an IPL port:

1. Click on **Network Node Processor Management** in the 3746-9x0 menu
2. Double-click on **Controller Configuration and Management**

Note: In all above cases, **Manage ESCON Processors** is still valid for display purpose.

IPL and Loading the Network Control Program

This procedure explains how to IPL the CCU(s) and load the control program (NCP) into the 3745.

Note: To perform this procedure on the **3746-900** you must use MOSS-E functions. Refer to the *Basic Operations Guide*, SA33-0177.

Step 1

Step 2 If you have a dual CCU controller:

or or then or then

Otherwise, continue with the next step.

Step 3 or then

If you are loading the control program from the 3745 fixed disk (using the MOSS DII function), go to Step 6 on page 5-19.

Otherwise, continue with the next step.

- Step 4** When the IPL has completed phase 4, the following message is displayed for each CCU undergoing IPL:

IPL PHASE 4 ENABLED CA xxx...

If other messages appear or the letter U appears anywhere after CA, refer to the *Basic Operations Guide*, SA33-0177, for an explanation.

- Step 5** Call the host operator and ask for the control program(s) to be loaded into your communication controller. Let the IPL continue, no additional 3745 operator action is required.

- Step 6** When the IPL is finished, the following message is displayed once for each CCU undergoing IPL:

IPL COMPLETE

If other messages appear, refer to the *Basic Operations Guide*, SA33-0177, for an explanation.

F1

You have finished this procedure, continue with other integration procedures as needed.

Note: You must at least do “Saving MOSS from Fixed Disk onto Diskettes” when you have finished all other integration procedures.

Saving MOSS from Fixed Disk onto Diskettes

The following procedure is used to backup the contents of the 3745 fixed disk onto removable 1.2 MB diskettes.

The MOSS must be off-line or alone:

- If the MOSS is **alone** or **off-line**, begin at Step 10 on page 5-20
- If the MOSS is **on-line**, then for a:
 - Dual CCU 3745 begin at Step 1
 - Single CCU 3745 begin at Step 8 on page 5-20.

Step 1 **C** **S** **R** **Enter**

Step 2 **1** **Enter**

Step 3 **F1**

Step 4 **M** **O** **F** **Enter**

When this message is displayed:

MOSS-OFFLINE

continue with the next step.

Step 5 **C** **S** **R** **Enter**

Step 6 **2** **Enter**

Step 7

Step 8

When this message is displayed:

MOSS-OFFLINE

continue with the next step.

Step 9

Step 10 To copy your disk onto diskettes, you need five or six PC diskettes. You can either use the set of backup diskettes located in the diskette holder on the left of the 3745 control panel, or use new diskettes.

If you use new diskettes, they should be part number 2HC 6009649 or equivalent double-sided, high-capacity, 5.25-inch diskettes.

Step 11 Your diskettes must be formatted. The set of backup diskettes that came with the 3745 are already formatted. If the new diskettes are not formatted, format them using the diskette initialization function:

See the *Advanced Operations Guide*, SA33-0097.

Otherwise, continue with the next step.

Step 12

Step 13 Enter the diskette identification. Use from one to eight alphanumeric characters. You may use blanks. Then:

Step 14 Insert PRIMARY diskette. When it is in place:

Step 15 When you see the following message:
DISK SAVE ONTO PRIMARY DISKETTE COMPLETED
REMOVE DISKETTE THEN PRESS SEND

remove the diskette, then:

Step 16 Repeat Steps 14 and 15 for the secondary, third, fourth, and fifth diskettes when prompted.

Note: For Models A, there is a sixth diskette.

Step 17 Note the information about the date, engineering change (EC), and the IDs on each diskette, then:

Step 18 You have finished this procedure. If you want to put the MOSS on-line, then:

- If the MOSS is **off-line**, then go to "Putting the MOSS On-Line" on page 5-21.
- If the MOSS is **alone**, then go to "IPL and Loading the Network Control Program" on page 5-18.

Otherwise, this is the last procedure done.

To log off:

Putting the MOSS On-Line

The following procedure puts the MOSS on-line:

- If the MOSS is **alone**, then go to “IPL and Loading the Network Control Program” on page 5-18.
- If the MOSS is **off-line**, then for a:
 - Dual CCU 3745, begin at Step 1
 - Single CCU 3745, begin at Step 8.

Step 1

Step 2

Step 3

Step 4

When this message is displayed:

MOSS-ONLINE

continue with the next step.

Step 5

Step 6

Step 7

Step 8

When the following message is displayed:

MOSS-ONLINE

If you have a:

- Single CCU 3745, go to Step 10.
- Dual CCU 3745, continue with the next step.

Step 9

Step 10 You have finished this procedure, continue with other integration procedures or log OFF:

Part 3. Appendices

Appendix A. LSS Characteristics and Line Weights

This appendix provides the rules for calculating weights of the lines attached to the low-speed scanners (LSS).

Characteristics of the LSSs

Table A-1 gives some characteristics of the LICs 1 to 4. For LICs 5 and 6, refer to the *LIC5/6 Migration and Integration Guide*, SA33-0416 or an earlier version of the *Connection and Integration Guide*, SA33-0129.

	LIC 1	LIC 3	LIC 4A	LIC 4B
Line Speed	Up to 19 200 bps	Up to 256 kbps	Up to 9600 bps	9600 bps to 256 kbps
Number of Ports	4	1	4	1
Protocols	Asynchronous (start-stop) Synchronous (SDLC, BSC)	Synchronous (SDLC, BSC)	Synchronous (SDLC)	Synchronous (SDLC)
ITU-T Interface	V.24, V.25, V.25 bis, X.20 bis, X.21 bis	V.35	X.21	X.21, X.24

Line Weight Calculation

The line weight is the percentage of the low-speed scanner capacity that the line uses. For example, five lines each with a weight of 20 take up 100% of the capacity of a low-speed scanner. Spare (unused) lines have a weight of zero.

The line weight is given by the following formula: **Weight = Line Speed / C**.

"C" is a coefficient related to the line protocol.

The values of the coefficient "C" are given in Table A-2 for LIC types 1, 3, 4A and 4B. For LIC types 5 and 6, refer to the *LIC5/6 Migration and Integration Guide*, SA33-0416.

Line Protocol	LIC types 1 and 4A (Up to 4 LICs per LSS)	LIC types 1 and 4A (More than 4 LICs per LSS)	LIC types 3 and 4B
SDLC Duplex	1920	1536	2560
SDLC Half-Duplex	3456	3072	4052
BSC EBCDIC under NCP	3456	3072	4052
BSC under EP	3456	3072	4052
BSC ASCII under NCP	2420	2016	3041
Start-stop	43 x no of bits/char	43 x no of bits/char	

Scanner Capacity

The maximum number of LIC positions supported per low-speed scanner depends on the line with the highest transmission speed connected to the scanner, and is limited by the LIC enclosure capacity.

For LIC Types 3 and 4B

You can calculate the scanner capacity according to the formula:

$$\frac{307\ 200}{\text{Maximum Speed}}$$

The results are given in Table A-3:

Maximum Line Speed	Maximum Number of One-Port LICs
256 000	1
230 400	1
128 000	2
72 000	4
64 000	4
57 600	5
56 000	5
50 000	6
48 000	6
40 800	7
38 400	8
24 000	8
20 400	8
19 200	8

For LIC Types 1 and 4A

You can calculate the scanner capacity according to the formula:

$$\frac{307\ 200}{4 \times \text{Maximum Speed}}$$

The results are given in Table A-4:

Maximum Line Speed	Maximum Number of Four-Port LICs
19 200	4
16 800	4
14 400	5
12 000	6
9 600	8

For LIC Types 5 and 6

Refer to the *LIC5/6 Migration and Integration Guide*, SA33-0416 or earlier version of the *Connection and Integration Guide*, SA33-0129.

Mixing Line Interface Couplers

To calculate the capacity of a low-speed scanner (LSS) connecting LICs with one or four ports, the following rules apply:

1. One-port LICs : LIC types 3, 4B.
2. Four-port LICs: LIC types 1 and 4A.

Mixing One-Port and Four-Port LICs

If one-port LICs are mixed with four-port LICs on the same scanner, you should consider:

- The permissible number of one-port LICs with the highest speed.
- The permissible number of four-port LICs with the highest speed.

Then, compare the two numbers and use the lower number.

Spare Lines

Spare (unused) lines have a weight of zero.

Selective Scanning

For more details on selective scanning, refer to the *Introduction*, GA33-0092 (for Models 210 to 610) or GA33-0138 (for Models 130 to 170). This information also applies to the Models A.

Unlike LICs in earlier communication controllers, 3745 LICs are only scanned if at least one of the lines connected to them is activated. LICs with inactive lines do not contribute to the scanner load.

Note: A LIC leaves the scan ring only after all the active lines on the LIC are deactivated by a Disable command from the control program. An X.21 DTE Clear command to a X.21 switched line does not disable the line for selective scanning.

Appendix B. Communication Line Processor Characteristics and Line Weights

This appendix explains:

- The communication line processor (CLP) characteristics (interfaces and connectivity)
- The standard line weights and the associated assumptions about the traffic and lines
- How the 3746 configurator, CF3745, assigns communication lines to CLPs using these line weights.

Characteristics of the CLPs

The communication lines can operate in half- or full-duplex mode and use the SDLC, PPP, Frame-relay, or X.25 line protocol, but not BSC and asynchronous (start-stop) line protocols. The primary access to Euro-ISDN via LIC 16 uses Frame-relay framing.

Note: ISDN connections are not supported by the 3746 network node nor the 3746 IP router. They are supported by the 3746-900 with the necessary programming support: NCP for SNA and CNN controlled traffic for APPN.

The communication line adapters support:

- V.24 leased and switched lines (600 bps up to 28.8 kbps)
- V.35 leased lines (56 kbps up to 2.048 mbps)
- X.21 leased lines (600 bps up to 2.048 mbps)
- V.25 bis protocol over V.24 switched lines.

The 3746-900 does not support the ITU-T X.21 switched lines.

If necessary, adapters configured in the 3745 can compliment the 3746-900 configuration to provide support for:

- BSC lines
- Asynchronous (start-stop) lines
- Low speed X.21 switched lines
- Emulation Program (EP).

Communication Line Processor Connectivity

The maximum physical connectivity of one CLP can be either:

- 4 high-speed lines up to 2 mbps
- 32 medium-speed lines up to 256 kbps
- 120 medium- and low-speed lines up to 64 kbps being either:
 - (V35/X.21) line interfaces
 - (V24) line interfaces

The CLP connects up to four line interface couplers (LICs) in any mix.

The LIC 12 provides one line interface (either ITU-T V.35 or X.21) operating at speeds up to 2 mbps.

The LIC 11 connects up to 30 lines (ITU-T V.24, V.35, and X.21) at speeds up to 64 kbps, or 8 lines (ITU-T V.35 and X.21) at speeds up to 256 kbps, or a mixture of these line speeds. All 30 line interfaces, the active remote connectors (ARCs), are housed in two line connection boxes (LCBs) of 15 slots each. This pair of LCBs is connected to a LIC 11 via a single cable up to 105 m long.

The LIC 16 provides Primary Rate Interface (PRI) ISDN operating at 2.048 mbps.

If the speed of a line is greater than 64 kbps, selective scanning is used to prevent the unnecessary scanning of the remaining unused slots in the LCB area.

The maximum operational capacity of the CLP depends on your specific network and traffic characteristics.

Characteristics of LIC Types 11, 12, and 16

<i>Table B-1. Characteristics of the LIC Types 11, 12 and 16</i>			
	LIC Types		
	LIC 11	LIC 12	LIC 16
Protocol	PPP, SDLC, Frame Relay, X.25	SDLC, Frame Relay, X.25	Euro-ISDN on D channel Frame-relay on B channel
Line Speeds	600 bps to 256 kbps	56kbps to 2.048 mbps	1 D channel at 64 kbps 30 B channel at 64 kbps
ITU-T Interface	V.24, V.25 Bis, V.35, X.21 (Note 1)	V.35 or X.21 (Note 2)	G703, G704, G706, G732
Number of Ports	Up to 30 (Note 3)	1	1
Cable Lengths (m)	1.3, 7, 15, 35, 70, 105	(Note 4)	30
	Low-Speed Lines	Medium-Speed Lines	
ARC Interface	V.24 (Note 1)	V.35 and X.21	
Line Speed	Up to 28.8 kbps	Up to 256 kbps	
Notes:			
1. Other interfaces (such as X.21 Bis) are supported using the appropriate 3745 cable. Refer to the <i>Migration and Planning Guide</i> , GA33-0183 for part numbers and cable lengths.			
2. Depends on the cable used.			
3. They are multiplexed over the cable that connects the LIC 11 to a pair of LCBs.			
4. Refer to the <i>Migration and Planning Guide</i> , GA33-0183.			

For more information about the ARCs, refer to *Migration and Planning Guide*, GA33-0183.

Maximum Configuration of a 3745 with a 3746-900

Table B-2 gives the maximum configuration of the 3745 Models A with only a 3746-900 attached. **There are no 3746-Axxs or Lxxs installed.**

Note: Some items in Table B-2 are mutually exclusive. Therefore, not all the maximum connection capabilities are possible on the same machine.

The maximum operational capacity may be lower than the maximum physical capacity given in table. For example, the maximum number of active lines (600) in a 3746-900 can be reached with a mix of line speeds ranging from 600 bps up to 64 kbps.

<i>Table B-2. Maximum Configurations of the 3745s with an Attached 3746-900</i>							
Configuration Types ¹	Adapter Types	Frame	3745 Model (Base Frame Only)				
			17A	21A	31A	41A	61A
3745 Central Control Units (CCU)	-	3745	1	1	1	2	2
Maximum Storage (MB per CCU)	-	3745	8	8	16	8	16
Parallel channel adapter ports	CA	3745	4	8	8	8	8
ESCON channel adapter ports	ESCA	3746-900	16	16	16	15	15
Token-ring LAN ports (4/16 mbps)	TIC 2	3745	2	8	8	8	8
	TIC 3	3746-900	33	33	33	32	32
Lines up to 19.2 kbps	LIC1 & 4A	3745	96	128	128	128	128
Lines up to 28.8 kbps	ARC 1	3746-900 ²	600 ³	600 ³	600 ³	600 ³	600 ³
Lines up to 64 kbps	LIC3 & 4B ARC 3 & 4	3745	24	32	32	32	32
		3746-900 ²	600 ³	600 ³	600 ³	600 ³	600 ³
Lines up to 256 kbps	LIC3 & 4B ARC 3 & 4 LIC12	3745	6	8	8	8	8
		3746-900 ²	256	256	256	240	240
Lines up to 2 mbps	HSS LIC12	3745	2	8	8	8	8
		3746-900 ²	32	32	32	30	30
Ethernet 2.0 ports	ELA TIC3 ⁴	3745	4	16	16	16	16
		3746-900	4	4	4	4	4

Notes:

- Some items are mutually exclusive. Therefore, not all the maximum connection capabilities are possible on the same machine.
The maximum operational capacity may be lower than the maximum physical capacity given above. For example, the maximum number of active lines in the 3746-900 (600) can be reached with a mix of lines having speeds in the range from 600 bps to 64 kbps.
- Up to 120 lines can be controlled by the 3746 network node and IP router. The remaining lines are controlled by NCP.
- Even with the second expansion enclosure, the 3746-900 maximum configuration is 600 logical lines
- Attached to an Ethernet Bridge feature.

Configuring Communication Lines on the 3746-900 (Line Weights)

The CLPs perform the data link control and traffic routing for the lines connected to the 3746-900. In the 3746-900, the CLPs also perform the data link control for the lines activated by the NCP. The contribution of an individual line to the CLP load depends on the:

- Traffic type: IP, HPR/ANR, HPR/RTP, APPN/DLUR, or NCP
- Line speed
- Line protocol (Frame-relay, SDLC, X.25, PPP)
- Type of mode: duplex or half-duplex
- Percentage of line utilization, including messages sent by users and applications, control information (such as acknowledgements, status frames (ANR), and so on). Line utilization is mainly influenced by the size and rate of data messages exchanged between users and applications.

CF3745 Hardware Configurator (Standard Line Weights)

Standard Line Weight Assumptions

The 3746 hardware configurator (CF3745) assigns lines to the CLPs by using standard line weights. For a given speed, this line weight represents the line contribution to the CLP load for a typical line utilization (%) and mix of traffic. The CF3745 assigns the lines to the CLPs without exceeding 90% of CLP load under the assumptions of the standard line weights.

Line Speed Range	Line Utilization (see note)
Up to 4.8Kbps	40%
Up to 28.8Kbps	45%
Up to 64Kbps	50%
Up to 256Kbps	45%
Up to 2.048Mbps	40%
Note: Line utilization includes user data, control traffic, header/trailer, and so on.	

Traffic Type	Transaction Size: Bytes (see note)	Percentage of Transactions
Transaction Processing	128/128	20%
Interactive (3270-like)	40/1000	50%
Batch/File Transfer/Image	0/2000	15%
Batch/File Transfer/Image	0/4000	15%
Note: For each direction, in or out of the 3746, size of the data message created by the sending workstation or application (0 means that the data traffic is in a single direction, in or out).		

For a given transmission speed, Table B-5 on page B-5 shows the standard line weights. The corresponding standard CLP connectivity is shown in Table B-6 on

page B-6. The weights and number of lines per CLP are indicated for the possible line protocols, SDLC, Frame Relay, PPP, X.25, and traffic types. Most of the standard default parameters of the CF3745 performance model are assumed for the standard line weights.

For more information, refer to the *Migration and Planning Guide*, GA33-0183.

Standard Line Weights and CLP Connectivity

The line weights corresponding to the “Standard Line Weight Assumptions” on page B-4 are used by CF3745 to determine the required number of CLPs and to automatically assign the lines to these CLPs. The CF3745 authorizes a maximum CLP weight of 100, which corresponds to a theoretical CLP load of 90%.

The actual required number of CLPs, as determined by CF3745, also depends on the physical connectivity requirements.

Table B-5. Standard Line Weights

Line Speeds (Kbps)	Assumed Line Utilization	SDLC and Frame Relay			PPP and Frame Relay	X.25			
		APPN DLUR	ANR	RTP	IP	APPN DX25	ANRX25	RTPX25	IPX25
2048	40%	67	20	100 ²	16	100 ²	94	100 ²	100 ²
1544		50	15	100	12	100 ²	70	100 ²	80
1024		34	10	68	8	85	48	100 ²	54
512		17	5	34	4	42	24	56	27
256	45%	9.6	2.9	19.2	2.2	24	13.5	32	15.4
128		4.9	1.5	9.6	1.1	12.2	6.9	16	7.8
96		3.9	1.2	7.8	0.9	9.7	5.5	13	6.2
64	50%	3.5	1.1	7.0	0.8	8.7	4.9	11.5	5.6
56		3.3	1.0	6.6	0.6	8.2	4.6	10.9	5.3
48		3.2	0.9	6.4	0.4	8.0	4.5	10.5	5.1
28.8	45%	2.5	0.75	5.0	0.35	6.2	3.5	8.2	4.0
19.2		2.0	0.6	4.0	0.3	5.0	2.8	6.6	3.2
14.4		1.75	0.5	3.5	0.25	4.4	2.5	5.8	2.8
9.6		1.5	0.45	3.0	0.2	3.7	2.1	5.0	2.4
4.8	40%	1.2	0.35	2.4	0.15	3.0	1.7	4.0	1.9
2.4		1.05	0.3	2.1	0.15	2.6	1.5	3.5	1.7
1.2		1.0	0.3	2.0	0.15	2.5	1.4	3.3	1.6

Notes:

1. The line weight for an intermediate speed is the weight corresponding to the nearest higher speed in the table.
2. Percentage indicated in column ‘Assumed Line Utilization’ may not be reached.
3. Spare lines (unused and not activated) and backup lines have a weight of zero.

Table B-6. Standard CLP Connectivity

Line Speeds (Kbps)	SDLC and Frame Relay			PPP and Frame Relay	X.25			
	APPN DLUR	ANR	RTP	IP	APPN DX25	ANRX25	RTPX25	IPX25
2048	1	4	1 ²	4	1 ²	1	1 ²	1 ²
1544	2	4	1	4	1 ²	1	1 ²	1
1024	3	4	1	4	1	2	1 ²	1
512	4	4	2	4	2	4	1	3
256	10	32	4	32	4	7	3	6
128	20	32	10	32	8	14	6	12
96	25	32	12	32	10	18	7	16
64	28	90	14	120	11	20	8	17
56	30	100	15	120	12	21	9	18
48	31	111	15	120	12	22	9	19
28.8	40	120	20	120	16	28	12	25
19.2	50	120	25	120	20	35	15	31
14.4	57	120	28	120	22	40	17	35
9.6	66	120	33	120	27	47	20	41
4.8	83	120	41	120	33	58	25	52
2.4	95	120	47	120	38	66	28	58
1.2	100	120	50	120	40	71	30	62

Notes:

- The connectivity is the maximum number of lines authorized by the CF3745, assuming that all the lines:
 - Have the same speed
 - Carry a single traffic type (APPNDLUR, ANR, IP, and so on.)
- Line utilization may not reach the percentages indicated in Table B-5.

For more information, refer to the *Migration and Planning Guide*, GA33-0183.

Appendix C. Bibliographies

Customer Documentation for the IBM 3745 (Models 210, 310, 410, 610, 21A, 31A, 41A, and 61A), and 3746 (Model 900)







<p><i>Table C-1 (Page 1 of 4). Customer Documentation for the 3745 Models x10 and x1A, and 3746 Model 900</i></p>		
<p>This customer documentation has the following formats:</p>		
		
<p>Finding Information</p>		
<p style="text-align: right;">3745 Models A and 3746 Books</p> <p>Starting with engineering change (EC) F12380, all of the books in the 3745 Models A and 3746 library are available on the CD-ROM that contains the Licensed Internal Code (LIC) for this EC.</p>		
	<p>SA33-0172</p>	<p>IBM 3745 Communication Controller Models 210 to 61A IBM 3746 Expansion Unit Model 900 Customer Master Index¹</p> <p>Provides references for finding information in the customer documentation library.</p>
<p>Evaluating and Configuring</p>		
	<p>GA33-0092</p>	<p>IBM 3745 Communication Controller Models 210, 310, 410, and 610 Introduction</p> <p>Gives an introduction about the IBM Models 210 to 610 capabilities. For Models A refer to the <i>Overview</i>, GA33-0180.</p>
	<p>GA33-0180</p>	<p>IBM 3745 Communication Controller Models A² IBM 3746 Nways Multiprotocol Controller Models 900 and 950 Overview</p> <p>Gives an overview of connectivity capabilities within SNA, APPN, and IP networking.</p>

Table C-1 (Page 2 of 4). Customer Documentation for the 3745 Models x10 and x1A, and 3746 Model 900

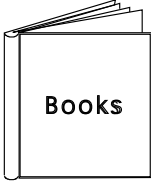
	GA33-0457	<p>IBM 3745 Communication Controller Models A² IBM 3746 Expansion Unit Model 900 Models 900 and 950</p>
<p>Planning Guide</p>		
<p>Planning for:</p>		
<ul style="list-style-type: none"> • Field upgrades • Service processor and alert management configuration • Network integration (NCP, APPN, and IP control) • Physical installation. 		
<p>Preparing Your Site</p>		
	GC22-7064	<p>IBM System/360, System/370, 4300 Processor Input/Output Equipment Installation Manual-Physical Planning (Including Technical News Letter GN22-5490)</p>
<p>Provides information for physical installation of the 3745 Models 130 to 610. For 3745 Models A and 3746 Model 900, refer to the <i>Planning Guide</i>, GA33-0457.</p>		
	GA33-0127	<p>IBM 3745 Communication Controller Models 210, 310, 410, and 610</p>
<p>Preparing for Connection</p>		
<p>Helps for preparing the 3745 Models 210 to 610 cable installation. For 3745 Models A refer to the <i>Connection and Integration Guide</i>, SA33-0129.</p>		
<p>Preparing for Operation</p>		
	GA33-0400	<p>IBM 3745 Communication Controller All Models³ IBM 3746 Nways Multiprotocol Controller Models 900 and 950</p>
<p>Safety Information¹</p>		
<p>Provides general safety guidelines.</p>		
	SA33-0129	<p>IBM 3745 Communication Controller All Models³ IBM 3746 Nways Multiprotocol Controller Model 900</p>
<p>Connection and Integration Guide¹</p>		
<p>Contains information for connecting hardware and integrating network of the 3745 and 3746-900 after installation.</p>		
	SA33-0416	<p>Line Interface Coupler Type 5 and Type 6 Portable Keypad Display</p>
<p>Migration and Integration Guide</p>		
<p>Contains information for moving and testing LIC types 5 and 6.</p>		

Table C-1 (Page 3 of 4). Customer Documentation for the 3745 Models x10 and x1A, and 3746 Model 900









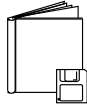

	SA33-0158	<p>IBM 3745 Communication Controller All Models³ IBM 3746 Nways Multiprotocol Controller Model 900</p> <p>Console Setup Guide¹</p>
<p>Provides information for:</p> <ul style="list-style-type: none"> • Installing local, alternate, or remote consoles for 3745 Models 130 to 610 • Configuring user workstations to remotely control the service processor for 3745 Models A and 3746 Model 900 using: <ul style="list-style-type: none"> – DCAF program – Telnet Client program. 		
Customizing Your Control Program		
	SA33-0178	<p>Guide to Timed IPL and Rename Load Module</p>
<p>Provides VTAM procedures for:</p> <ul style="list-style-type: none"> • Scheduling an automatic reload of the 3745 • Getting 3745 load module changes transparent to the operations staff. 		
Operating and Testing		
	SA33-0098	<p>IBM 3745 Communication Controller All Models⁴</p> <p>Basic Operations Guide¹</p>
<p>Provides instructions for daily routine operations on the 3745 Models 130 to 610.</p>		
	SA33-0177	<p>IBM 3745 Communication Controller Models A² IBM 3746 Nways Multiprotocol Controller Model 900</p> <p>Basic Operations Guide¹</p>
<p>Provides instructions for daily routine operations on the 3745 Models 17A to 61A, and 3746 Model 900 operating as an SNA node (using NCP), APPN/HPR Network Node, and IP Router.</p>		
	SA33-0097	<p>IBM 3745 Communication Controller All Models³</p> <p>Advanced Operations Guide¹</p>
<p>Provides instructions for advanced operations and testing, using the 3745 MOSS console.</p>		
	On-line Information	<p>Controller Configuration and Management Application</p>
<p>Provides a graphical user interface for configuring and managing a 3746 APPN/HPR Network Node and IP Router, and its resources. Is also available as a stand-alone application, using an OS/2 workstation. Defines and explains all the 3746 network node and IP configuration parameters through its on-line help.</p>		

Table C-1 (Page 4 of 4). Customer Documentation for the 3745 Models x10 and x1A, and 3746 Model 900

	SH11-3081	<p>IBM 3746 Nways Multiprotocol Controller Models 900 and 950</p> <p>Controller Configuration and Management: User's Guide⁵</p>
Explains how to use CCM and gives examples of the configuration process.		
Managing Problems		
	SA33-0096	<p>IBM 3745 Communication Controller All Models³</p> <p>Problem Determination Guide¹</p>
A guide to perform problem determination on the 3745 Models 130 to 61A.		
	On-line Information	<p>Problem Analysis Guide</p>
An on-line guide to analyze alarms, events, and control panel codes on:		
<ul style="list-style-type: none"> • IBM 3745 Communication Controller Models A² • IBM 3746 Nways Multiprotocol Controller Models 900 and 950. 		
	SA33-0175	<p>IBM 3745 Communication Controller Models A²</p> <p>IBM 3746 Expansion Unit Model 900</p> <p>IBM 3746 Nways Multiprotocol Controller Model 950</p> <p>Alert Reference Guide</p>
Provides information about events or errors reported by alerts for:		
<ul style="list-style-type: none"> • IBM 3745 Communication Controller Models A² • IBM 3746 Nways Multiprotocol Controller Models 900 and 950. 		
<p>¹ Documentation shipped with the 3745.</p> <p>² 3745 Models 17A to 61A.</p> <p>³ 3745 Models 130 to 61A.</p> <p>⁴ Except 3745 Models A.</p> <p>⁵ Documentation shipped with the 3746-900.</p>		

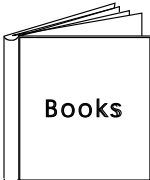
Additional Customer Documentation for the IBM 3745 Models 130, 150, 160, 170, and 17A

Table C-2. Additional Customer Documentation for the 3745 Models 1x0 and 17A		
This customer documentation has the following format:		
		
Finding Information		
	SA33-0142	<p>IBM 3745 Communication Controller Models 130, 150, 160, 170, and 17A IBM 3746 Expansion Unit Model 900</p> <p>Customer Master Index¹</p> <p>Provides references for finding information in the customer documentation library.</p>
Evaluating and Configuring		
	GA33-0138	<p>IBM 3745 Communication Controller Models 130, 150, and 170</p> <p>Introduction</p> <p>Gives an introduction about the IBM Models 130 to 170 capabilities, including Model 160.</p> <p>For Model 17A refer to the <i>Overview</i>, GA33-0180.</p>
Preparing Your Site		
	GA33-0140	<p>IBM 3745 Communication Controller Models 130, 150, 160, and 170</p> <p>Preparing for Connection</p> <p>Helps for preparing the 3745 Models 130 to 170 cable installation.</p> <p>For 3745 Model 17A refer to the <i>Connection and Integration Guide</i>, SA33-0129.</p>
<p>¹ Documentation shipped with the 3745.</p>		

Abbreviations, Glossary, and Index

List of Abbreviations

ACF	advanced communications function	HPR	high performance routing
APPN	Advanced Peer-to-Peer Networking	HSS	high-speed scanner
ANR	automatic network routing	INN	intermediate network node
ARC	active remote connector	IML	initial microcode load
AUI	access unit interface	IP	internet protocol
BAN	boundary access node	IPL	initial program load
BNN	boundary network node	ISDN	integrated service digital network
bps	bits per second	ISO	international organization for standardization
BSC	binary synchronous communication	ITU-T	International Telecommunication Union - Telecommunication (formerly CCITT)
CA	channel adapter	kbps	kilo bits per second
CCITT	Comité Consultatif International Télégraphique et Téléphonique. The International Telegraph and Telephone Consultative Committee (now ITU-T)	LAN	local area network
CCM	controller configuration and management	LCB	line connection box
CCU	central control unit	LCBB	line connection box base
CDF	configuration data file	LCBE	line connection box expansion
CDF-E	configuration data file - extended	LIB1	line interface base, type 1
CLP	communication line processor	LIB2	line interface base, type 2
CNN	composite network node	LIC	line interface coupler
CPC	customer power control	LIU1	line interface coupler unit, type 1
DCAF	distributed access facility	LIU2	line interface coupler unit, type 2
DCE	data circuit-terminating equipment	LSS	low-speed scanner
DLU	dependent logical unit	LU	logical unit
DLUR	dependant logical unit requester	MAE	multiaccess enclosure (IBM 2216 base)
DTE	data terminal equipment	MAU	multistation access unit
EBCDIC	extended binary-coded decimal interchange code	MB	mega bytes
EC	engineering change	mbps	mega bits per second
ELA	Ethernet LAN adapter	mm	millimeter
EP	emulation program	MOSS	maintenance and operator subsystem
ESCON	Enterprise Systems Connector	MOSS-E	maintenance and operator subsystem - extended
ESD	electrostatic discharge	NCP	network control program
FCC	federal communications commission	NPM	netview performance monitor

PPP	point-to-point protocol	TRA	token-ring adapter
RLSD	received line signal detector	URL	uniform resource locator
RETAIN	remote technical assistance information network	UTP	unshielded twisted pair
RSF	remote support facility	VTAM	virtual telecommunications access method
SDLC	synchronous data link control	3745	IBM 3745 Communication Controller
SNA	Systems Network Architecture	3746-900	IBM 3746 Nways Multiprotocol Controller Model 900
STP	shielded twisted pair	3746-900IP	3746-900 operating as IP Router
TCAM	telecommunications access method	3746-900NN	3746-900 operating as Network Node
TIC2	token-ring interface coupler, type 2		
TIC3	token-ring interface coupler, type 3		

Glossary

This glossary defines new terms used in this manual. It also includes terms and definitions from the *IBM Dictionary of Computing*, SC20-1699.

Advanced Communication Function (ACF). A group of IBM licensed programs, principally VTAM programs, TCAM, NCP, and SSP, that use the concepts of Systems Network Architecture (SNA), including distribution of function and resource sharing.

advanced peer-to-peer networking (APPN). An extension of SNA featuring: (a) greater distributed network control that avoids critical hierarchical dependencies, thereby isolating the effects of single point failure; (b) dynamic exchange of network topology information to foster ease of connection reconfiguration, and adaptive route selection; (c) dynamic definition of network resources; and (d) automated resource registration and directory lookup. APPN extends the LU 6.2 peer orientation for end-user services to network control and supports multiple LU types, including LU 2, LU 3, and LU 6.2.

asynchronous transmission. Data transmission in which transmission of a character or a block of characters can begin at any time but in which the bits that represent the character or block have equal time duration. Contrast with *synchronous transmission*.

binary synchronous transmission (BSC). A form of telecommunication line control that uses a standard set of transmission control character sequences, for binary synchronous transmission of binary-coded data between stations. Contrast with SDLC.

boundary network node (BNN). (1) In SNA, deprecated term for *boundary node (BN)*. (2) In NCP, deprecated term for *peripheral node*.

central control unit (CCU). In the 3745, the controller hardware unit that contains the circuits and data flow paths needed to execute instructions and to control its storage and the attached adapters.

channel adapter (CA). A communication controller hardware unit used to attached the controller to a System/370* data channel.

communication controller. A device that directs the transmission of data over the data links of a network; its operation may be controlled by a program executed in a processor to which the controller is connected or it may be controlled by a program executed within the device. Examples are the IBM 3705, IBM 3725/3726, IBM 3720, and IBM 3745 models 130, 150, 170, 210, 310, 410, and 610.

configuration data file (CDF). A 3745 MOSS file that contains a description of all the hardware features (presence, type, address, and characteristics).

configuration data file - extended (CDF-E). A MOSS-E file that contains a description of all the hardware features (presence, type, address, and characteristics).

control panel. A panel that contains switches and indicators for the customer's operator and service personnel.

control program. A computer program designed to schedule and to supervise the execution of programs of the controller.

control subsystem. The part of the controller that stores and executes the control program, and monitors the data transfers over the channel and transmission interfaces.

customer engineer. See IBM service representative

data circuit-terminating equipment (DCE). The equipment installed at the user's premises that provides all the functions required to establish, maintain, and terminate a connection, and the signal conversion between the data terminal equipment (DTE) and the line. For example, a modem is a DCE.

Note: The DCE may be a stand-alone equipment or integrated in the 3745.

data terminal equipment (DTE). That part of a data station that serves as a data source, data link, or both, and provides for the data communication control function according to protocols. For example, the 3745 can be a DTE.

dependent logical unit (DLU). Any logical unit (LU) that is made active by a command from the host system over a data link. Such logical units can be used only as secondary logical units, and can have only one active LU-to-LU session at a time. Contrast with independent logical unit.

direct attachment. The attachment of a DTE to another DTE without a DCE.

diskette. For IBM 3745 control panel, a thin, flexible magnetic disk, and its protective jacket, that records diagnostics, microcode, and files. Diskette size is 5"25. For the service processor the diskette size is 3"5.

Distributed Console Access Facility (DCAF). An IBM licensed program that lets a user at one workstation to remotely monitor, control, and operate another workstation.

extended binary-coded decimal interchange code (EBCDIC). A coded character set of 256 8-bit characters.

electrostatic discharge (ESD). An undesirable discharge of static electricity that can damage equipment and degrade electrical circuitry.

emulation program (EP). An IBM control program that allows a channel-attached 3705 or 3725 communication controller to emulate the functions of an IBM 270x device. See also NCP.

enterprise system connection (ESCON). A set of IBM products and services that provides a dynamically connected environment within an enterprise.

ESCON channel. A channel having an Enterprise System Connection channel-to-control-unit I/O interface that uses optical cables as a transmission medium.

ESCON channel adapter (ESCA). A communication controller hardware unit used to attach the controller to a host via ESCON fiber optics. An ESCA consists of an ESCON channel processor and an ESCON channel coupler.

Ethernet LAN adapter (ELA). Line adapter for Ethernet-type network, composed of one communication scanner processor card (CSP), and one Ethernet adapter card (EAC).

high-speed scanner (HSS). Line adapter for lines speeds up to 2 mbps. It is composed of a communication scanner processor (CSP) and a front-end high-speed scanner (FESH).

host processor. (1) A processor that controls all or part of a user application network. (2) In a network, the processing unit in which the access method for the network resides. (3) In an SNA network, the processing unit that contains a system services control point (SSCP). (4) A processing unit that executes the access method for attached communication controllers. Also called *host*.

IBM service representative. An individual in IBM who does maintenance services for IBM products or systems.

initial program load (IPL). The initialization procedure that causes the 3745 control program to begin operation.

input/output control (IOC). The circuit that controls the input/output from/to the channel adapters and scanners via the IOC bus.

integrated services digital network (ISDN). A digital end-to-end telecommunication network that supports multiple services including, but not limited to, voice and data.

internal clock function (ICF). A LIC function that provides a transmit clock for sending data, and retrieves a receive clock from received data, when DCEs or direct-attached terminal do not provide those timing signals.

international organization for standard (ISO). An organization of national standards bodies from various countries established to promote development of standards to help international exchange of goods and services, and develop cooperation in intellectual, scientific, technological, and economic activity.

International Telecommunication Union - Telecommunication (ITU-T). The specialized telecommunication agency of the United Nations,

established to provide standardized communication procedures and practices, including frequency allocation and radio regulations worldwide. (Formerly CCITT).

Internet Protocol (IP). In TCP/IP, a protocol that routes data from its source to its destination in an Internet environment.

LIC unit (LIU). A line interface coupler unit (LIU) consisting of:

- One power supply (PS) associated with
- Two line interface bases (LIBs), housing
- Multiplex cards, and
- Line interface coupler cards (LICs)

line adapter (LA). The part of the TSS, HPTSS, or TRSS that scans and controls the transmission lines. Also called *scanner*.

For the ESS the line adapters are Ethernet LAN adapters (ELAs).

For the TSS the line adapters are low-speed scanners (LSSs).

For the HPTSS the line adapters are high-speed scanners (HSSs).

For the TRSS the line adapters are token-ring adapters (TRAs).

line interface base (LIB). A board which houses:

- One multiplexer
- Up to eight LICs

line interface coupler (LIC). A circuit that attaches up to four transmission cables to the controller (from DTEs, DCEs or telecommunication lines).

local area network (LAN). A computer network located on a user's premises within a limited geographical area. Communication within a LAN is not subject to external regulation; however, communication across the LAN boundary may be subject to some form of regulation.

logical unit (LU). (1) In SNA, a port through which an end user accesses the SNA network in order to communicate with another end user and through which the end user accesses the functions provided by system services control points (SSCPs). An LU can support at least two

sessions, one with an SSCP and one with another LU, and may be capable of supporting many sessions with other logical units. (2) A type of network addressable unit that enables end users to communicate with each other and gain access to network resources.

low-speed scanner. Line adapter for lines up to 256 kbps. It is composed of a communication scanner processor (CSP) and a front-end low-speed scanner (FESL).

maintenance and operator subsystem (MOSS). The part of the 3745 that provides operating and servicing facilities to the user and IBM service representative.

maintenance and operator subsystem extended (MOSS-E). The licensed internal code loaded on the service processor fixed disk to provide maintenance and operator facilities to the user and IBM service representative.

microcode. A program that is loaded in a processor (for example, the MOSS processor) to replace a hardware function. The microcode is not accessible to the customer.

modem (modulator-demodulator). See DCE.

multipoint connection. A connection established among more than two data stations for data transmission. The connection may include switching facilities.

multistation access unit (MAU). In the IBM token-ring network, a wiring concentrator that connect up to eight lobes to a ring.

native mode. An IBM modulation scheme.

NetView Performance Monitor (NPM). An IBM licensed program that collects, monitors, analyses, and displays data relevant to the performance of a VTAM telecommunication network. It runs as an on-line VTAM application program.

Network Control Program (NCP). An IBM licensed program that provides communication controller support for single-domain, multiple domain, and interconnected network capability.

nonswitched line. A connection between systems or devices that does not have to be made by dialing. The connection can be point-to-point

or multipoint. The line can be leased or private. Contrast with *switched line*.

operator console. The IBM Operator Console that is used to operate and service the 3745 through the MOSS or the 3746-900 through the MOSS-E.

point-to-point connection. A connection established between two data stations for data transmission. The connection may include switching facilities.

Post Telephone and Telegraph (PTT). A generic term for the government-operated common carriers in countries other than the U.S.A. and Canada. Examples of the PTT are British Telecom in the United Kingdom, the Deutsche Bundespost in Germany, and the Nippon Telephone and Telegraph Public Corporation in Japan.

remote support facility (RSF). RSF provides IBM maintenance assistance when requested via the public switched network. It is connected to the IBM RETAIN database system.

scanner. A device that scans and controls the transmission lines. Also called *line adapter*.

secondary modem. A secondary device on a multipoint line.

service processor. The operator console for the Models 21A, 31A, 41A, and 61A, which is attached to the 3745 and 3746-900 via a token-ring LAN. It runs contiguously transferring code to and from the processors inside the controller.

service representative. See IBM service representative

services. A set of functions designed to simplify the maintenance of a device or system.

switched line. A transmission line with which the connections are established by dialing, only when data transmission is needed. The connection is point-to-point and uses a different transmission line each time it is established. Contrast with *nonswitched line*.

Synchronous Data Link Control (SDLC). A discipline for managing synchronous, code-transparent, serial-by-bit information transfer over a link connection. Transmission exchanges may be duplex or half-duplex over switched or nonswitched links. The configuration of the link connection may be point-to-point, multipoint, or loop. SDLC conforms to subsets of the Advanced Data Communication Control Procedures of the American National Standards Institute and High-Level Data Link Control (HDLC) of the International Standards Organization.

synchronous transmission. Data transmission in which the sending and receiving instruments are operating continuously at substantially the same frequency and are maintained, through correction, in a desired phase relationship. Contrast with *asynchronous transmission*.

systems network architecture (SNA). The description of the logical structure, formats, protocols, and operational sequences for transmitting information units through, and controlling the configuration and operation of, networks.

Telecommunications Access Method (TCAM). An access method used to transfer data between main storage and remote or local terminals.

telecommunication line. Any physical medium, such as a wire or microwave beam, that is used to transmit data.

time out. A time interval allotted for certain operations to occur.

token-ring interface coupler type 2 (TIC2). A circuit that attaches an IBM Token-Ring network to an IBM 3745.

token-ring interface coupler type 3 (TIC3). A circuit that attaches an IBM Token-Ring network to an IBM 3746-900 or 3746-950.

token-ring adapter (TRA). Line adapter for IBM Token-Ring Network, composed of one token-ring multiplexor card (TRM), and two token-ring interface couplers (TICs).

token-ring interface coupler (TIC). A circuit that attaches up to two IBM Token-Ring networks to the controller.

transmission line. The physical means for connecting two or more DTEs (via DCEs). It can be nonswitched or switched.

tributary modem. On a multipoint connection or a point-to-point connection using basic mode link control, any modem other than the control modem. See also secondary modem.

user access area. A specific area in the controller where the customer can install, remove, change, or swap LICs and TICs by himself.

user application network. A configuration of data processing products, such as processors, controllers, and terminals, for data processing and information exchange. This configuration may use

circuit-switched, packet-switched, and leased-circuit services provided by carriers or PTT. Also called a *user network*.

Virtual Telecommunications Access Unit (VTAM*). A set of programs that maintain control of the communication between terminals and application programs running under operating systems (DOS, OS/2).

V.24, V.25, V.25bis, V.35. ITU-T recommendations on telecommunication physical interfaces.

X.20bis, X.21, X.21bis, X.24. ITU-T recommendations on network access protocols and interfaces.

Index

A

ARC

- cable identification 3-21, 3-26
- identifying assembly A or B 3-18, 3-24
- installation 3-18, 3-24
- locating 3-2
- physical interface 3-21, 3-26
- removal 3-18, 3-24

AUI cable safety requirements 1-7, 2-4, 3-9

B

backing up the fixed disk 5-19

C

cables, unplugging or plugging

- 10BASE-T 3-9
- 3745 LIC 1-18, 2-13
- 3746-900 LIC 3-7
- ARCs 3-21, 3-26
- AUI 1-7, 2-4, 3-9
- CPC 1-18
- HSS 1-13
- MAE adapter cable 3-12
- operator console cable 1-15
- RSF 1-16
- TIC2 1-11, 2-7
- TIC3 3-5

CDF

- upgrade or update 5-7

CDF-E updating 5-1

CLP

- characteristics and line weights B-1

communication line processor

- characteristics B-1
- connectivity B-1
- line weight B-4

configuration

- saving (controller configuration) 5-5

connecting

- 3745 Models 1xx LICs and Cables 2-1
- 3745 Models x1x LICs and Cables 1-1
- 3746-900 ARC cables 3-1
- 3746-900 LIC cables 3-1
- 3746-900 TIC 3 cables 3-1
- tasks 3-2

controller

- saving the configuration 5-5

couplers, mixing line interface A-3

E

Ethernet LAN attachment cable

- plugging in 1-7, 2-4, 3-9
- unplugging 1-7, 2-4, 3-9

H

high-speed scanner adapter cable

- plugging in 2-8
- unplugging 2-8

I

identification

- 3745 LIC 1-20, 2-15
- 3746-900 LIC 3-8
- ARC assembly A or B 3-18, 3-24
- ARC cables 3-21, 3-26
- ARC physical interfaces 3-21, 3-26
- LCB types 3-14

IML

- scanner 5-18

installing

- 3745 LIC cable 1-18, 2-13
- 3746-900 LIC cable 3-8
- ARC 3-18, 3-24
- ARC cable 3-22, 3-24
- LCB 3-13, 3-17
- TIC2 cable 1-11, 2-7
- TIC3 cable 3-5

integrating

- initial installation 5-6
- later modification 5-6

integration

- 3745 4-1
- procedures for MOSS 5-5

IPL ports

- 3745 5-17
- 3746-900 5-18

L

later modification, integrating a 5-6

LCB

- grounding 3-16
- installation 3-13
- locations 3-2
- types 3-14

LIC 11

- characteristics B-2

LIC 12

- characteristics B-2

LIC 16

- characteristics B-2

line interface coupler

- 3745 LIC 1-18, 2-13
- 3745 LIC cable 1-18, 2-13
- 3746-900 identification 3-8
- 3746-900 location 3-2
- CLP characteristics B-1
- install 3745 LIC 1-18, 2-13
- LSS characteristics A-1
- plugging in 3746-900 LIC cable 3-7
- remove 3745 LIC 1-18, 2-13
- unplugging 3746-900 LIC cable 3-7

line weight

- calculation A-1
- communication line processor B-4
- LIC 1 A-2
- LIC 3 A-2
- LIC 4A A-2
- LIC 4B A-2
- low-speed scanners A-1
- mixing one-port and four-port LICs A-3

load Network Control Program 5-18

locating

- 3745 LIC 1-2, 2-2
- 3746-900 LIC 3-2
- ARC 3-2
- LCB 3-2
- TIC3 3-2

LSS line weight A-1

M

mixing line interface coupler A-3

MOSS

- integration procedures 5-5
- on-line 5-21

MOSS-E

- integration functions 5-1

multiaccess enclosure

- plugging in a TIC3 cable 3-12
- unplugging a TIC3 cable 3-12

O

operator console

- plugging in cable 2-9, 2-12
- unplugging cable 2-9, 2-12

P

password

- 3745 operations 5-14

physical interface, ARC 3-21, 3-26

plugging in

- 10BASE-T Cable 3-11
- 3745 LIC cable 1-18, 2-13
- 3746-900 LIC cable 3-7
- ARC cable 3-22, 3-28
- AUI cable 3-9
- customer power control cable 1-18, 2-12
- Ethernet LAN attachment cable 1-7, 2-4, 3-9
- high-speed scanner adapter cable 1-13, 2-8
- MAE adapter cable 3-12
- operator console cable 1-15, 2-9
- RSF cable 1-16, 2-11
- TIC2 cable 1-11, 2-7
- TIC3 cable 3-5

power ON

- scheduled 5-16

R

removing

- 10BASE-T cable 3-9
- 3746-900 LIC cable 3-7
- ARC 3-18, 3-24
- ARC cable 3-19, 3-24
- AUI cable 1-7, 2-4, 3-9
- MAE adapter cable 3-12
- TIC2 cable 1-11, 2-7
- TIC3 cable 3-5

RSF

- plugging in cable 2-11
- unplugging cable 2-11

S

save disk 5-19

saving operations

controller configuration 5-5

scanner capacity A-2

selective scanning A-3

set

power ON schedule 5-16

spare lines A-3

T

TIC2

plugging in a TIC2 cable 2-7

unplugging a TIC2 cable 2-7

TIC3

location 3-2

plugging in a TIC3 cable 3-5

unplugging a TIC3 cable 3-5

U

unplugging

3745 LIC cable 1-18, 2-13

3746-900 LIC cable 3-7

ARC cable 3-19, 3-24

customer power control cable 1-18, 2-12

Ethernet LAN attachment cable 1-7, 2-4, 3-9

high-speed scanner adapter cable 1-13, 2-8

MAE adapter cable 3-12

operator console cable 1-15, 2-9

RSF cable 1-16, 2-11

TIC2 cable 1-11, 2-7

TIC3 cable 3-5

unplugging

10BASE-T Cable 3-11

AUI cable 3-9

update

CDF 5-7

CDF-E 5-1

upgrade

CDF 5-7

Readers' Comments — We'd Like to Hear from You

3745 Communication Controller All Models
3746 Nways Multiprotocol Controller Model 900
Connection and Integration Guide
Publication No. SA33-0129-10

Please send us your comments concerning this book. We will greatly appreciate them and will consider them for later releases of the present book.

If you prefer sending comments by FAX or electronically, use:

- FAX: 33 4 93 24 77 97
- E-mail: FRIBMQF5 at IBMMAIL
- IBM Internal Use: LGERCF at LGEPROFS
- Internet: rcf_lagaude@vnet.ibm.com

In advance, thank you.

Your comments:

Name

Address

Company or Organization

Phone No.



Fold and Tape

Please do not staple

Fold and Tape

PLACE
POSTAGE
STAMP
HERE

IBM France
Centre d'Etudes et Recherches
Service 0798 - BP 79
06610 La Gaude
France

Fold and Tape

Please do not staple

Fold and Tape



Part Number: 26F1739

Printed in La Gaude by

